

Exemplar Problems

BIOLOGY

Class XII



राष्ट्रीय शैक्षिक अनुसंधान और प्रशिक्षण परिषद्
NATIONAL COUNCIL OF EDUCATIONAL RESEARCH AND TRAINING



FOREWORD

The National Curriculum Framework (NCF) – 2005 initiated a new phase of development of syllabi and textbooks for all stages of school education. Conscious effort has been made to discourage rote learning and to diffuse sharp boundaries between different subject areas. This is well in tune with the NPE–1986 and *Learning Without Burden -1993* that recommend child-centred system of education. The textbooks for Classes IX and XI were released in 2006 and for Classes X and XII in 2007. Overall the books have been well received by students and teachers.

NCF–2005 notes that treating the prescribed textbooks as the sole basis of examination is one of the key reasons why other resources and sites of learning are ignored. It further reiterates that the methods used for teaching and evaluation will also determine how effective these textbooks prove for making children's life at school a happy experience, rather than source of stress or boredom. It calls for reform in examination system currently prevailing in the country.

The position papers of the National Focus Groups on *Teaching of Science, Teaching of Mathematics and Examination Reform* envisage that the question papers, set in annual examinations conducted by the various Boards do not really assess genuine understanding of the subjects. The quality of question papers is often not upto the mark. They usually seek mere information based on rote memorisation, and fail to test higher-order skills like reasoning and analysis, let alone lateral thinking, creativity, and judgement. Good unconventional questions, challenging problems and experiment-based problems rarely find a place in question papers. In order to address to the issue, and also to provide additional learning material, the Department of Education in Science and Mathematics (DESM) has made an attempt to develop resource book of exemplar problems in different subjects at secondary and higher-secondary stages. Each resource book contains different types of questions of varying difficulty level. Some questions would require the students to apply simultaneously understanding of more than one chapters/units. These problems are *not* meant to serve merely as question bank for examinations but are primarily meant to improve the quality of teaching-learning process in schools. It is expected that these problems would encourage teachers to design quality questions on their own. Students and teachers should always keep in mind that examination and assessment should test comprehension, information, recall, analytical thinking and problem-solving ability, creativity and speculative ability.



A team of experts and teachers with an understanding of the subject and a proper role of examination worked hard to accomplish this task. The material was discussed, edited, and finally included in this resource book.

NCERT would welcome suggestions from students, teachers and parents which would help us to further improve the quality of material in subsequent editions.

Yash Pal

Chairperson

National Steering Committee

National Council of Educational

Research and Training

New Delhi
21 May 2008



PREFACE

The Department of Education in Science and Mathematics (DESM), National Council of Educational Research and Training (NCERT), initiated the development of 'Exemplar Problems' in science and mathematics for secondary and higher secondary stages after completing the preparation of textbooks based on National Curriculum Framework-2005.

The main objective of the book *Exemplar Problems in Biology* for class XII is to provide the teachers and students a large number of quality problems with varying cognitive levels to facilitate teaching-learning of concepts in Biology that are presented through the textbook for Class XII. It is envisaged that the problems included in this volume would help the teachers to design tasks to assess effectiveness of their teaching and to know about the achievement of their students besides facilitating preparation of balanced question papers for unit and terminal tests. The feedback based on the analysis of students' responses may help the teachers in further improving the quality of classroom instructions. In addition, the problems given in this book are also expected to help the teachers to perceive the basic characteristics of good quality questions and motivate them to frame similar questions on their own. Students can benefit themselves by attempting the exercises given in the book for self-assessment and also in mastering the basic techniques of problem solving. Some of the questions given in the book are expected to challenge the understanding of the concepts of biology of the students and their ability to apply them in novel situations.

The problems included in this book were prepared through a series of workshops organised by the DESM for their development and refinement involving practising teachers, subject experts from universities and institutes of higher learning, and the members of the biology group of the DESM whose names appear separately. We gratefully acknowledge their efforts and thank them for their valuable contribution in our endeavour to provide good quality instructional material for the school system.

I express my gratitude to Professor Krishna Kumar, Director, and Professor G. Ravindra, Joint Director, NCERT, for their valuable motivation and guidance from time to time. Special thanks are due to Dr. B. K. Tripathi, *Professor*, DESM for coordinating the programme, taking pains in editing and refinement of problems and for making the manuscript pressworthy.

We look forward to feedback from students, teachers and parents for further improvement of the contents of the book.

New Delhi

HUKUM SINGH
Professor and Head
Department of Education in
Science and Mathematics
National Council of Educational
Research and Training

CHILDREN'S BILL OF RIGHTS

A child is every person under the age of 18 years. Parents have the primary responsibility for the upbringing and development of the child. The State shall respect and ensure the rights of the child.



- I have the Right to express my views freely which should be taken seriously, and everyone has the Responsibility to listen to others. (Article 12,13)



- I have the Right to good health care, and everyone has the Responsibility to help others get basic health care and clean water. (Article 24)
- I have the Right to a good education, and everyone has the Responsibility to encourage all children to go to school. (Article 28,29,23)



- I have the Right to be loved and protected from harm and abuse, and everyone has the Responsibility to love and care for others. (Article 19)



- I have the Right to be included whatever my abilities, and everyone has the Responsibility to respect others for their differences. (Article 23)
- I have the Right to be proud of my heritage and beliefs, and everyone has the Responsibility to respect the culture and belief of others. (Article 29,30)



- I have the Right to a safe and comfortable home and everyone has the Responsibility to make sure all children have homes. (Article 27)



- I have the Right to make mistakes, and everyone has the Responsibility to accept we can learn from our mistakes. (Article 28)
- I have the Right to be well fed, and everyone has the Responsibility to prevent people from starving. (Article 24)

- I have the Right to a clean environment, and everyone has the Responsibility not to pollute it. (Article 29)

- I have the Right to live without violence (verbal, physical, emotional), and everyone has the Responsibility not to be violent to others. (Article 28,37)

- I have the Right to be protected from economic and sexual exploitation, and everyone has the Responsibility to ensure that no child is forced to work and is given a free and secure environment. (Article 32,34)

These rights and responsibilities are enshrined in the United Nations Convention on the Rights of the Child, 1989. It contains all the rights which children and young people have all over the world. The Government of India signed this document in 1992.



DEVELOPMENT TEAM

K. Muralidhar, *Professor*, Department of Zoology, University of Delhi, Delhi
Chief Advisor – Biology Textbook Development Committee, NCERT

MEMBERS

D. G. Rao, *Reader* (Zoology), Regional Institute of Education, Bhubaneswar
Deepti Srivastava, *PGT* (Biology), Sanskriti School, New Delhi
Dinesh Kumar, *Reader* (Zoology), Department of Education in Science and Mathematics (DESM), NCERT, New Delhi
J. P. Gaur, *Professor* (Botany), Banaras Hindu University, Varanasi
N.V.S.R.K. Prasad, *Reader* (Botany), Sri Venkateswara College, New Delhi
R. P. Singh, *Lecturer* (Biology), Rajkiya Pratibha Vikas Vidyalaya, Delhi
Sarath Chandran, *Reader* (Zoology), Sri Venkateswara College, New Delhi
Savithri Singh, *Principal*, Acharya Narendra Dev College, New Delhi
S. P. Sinha, *Professor* (Retd), Bhagalpur University, Bhagalpur
Sunita L Varte, *Lecturer* (Botany), DESM, NCERT, New Delhi
Urmi Bajpai, *Reader* (Biotechnology), Acharya Narendra Dev College, New Delhi
V. V. Anand, *Reader* (Botany), Regional Institute of Education, Mysore

MEMBER-COORDINATOR

B.K. Tripathi, *Professor* (Zoology), DESM, NCERT, New Delhi



ACKNOWLEDGEMENT

National Council of Educational Research and Training (NCERT) gratefully acknowledges the contribution of all the members who have contributed at different stages in the development of this book. The Council is grateful to all the concerned Heads of the Department and Principals for deputing their faculty members for this task.

NCERT, sincerely acknowledges the contributions of the members who participated in the review of the manuscripts – Dr. Ajit Kavathekar, *Reader (Botany)*, Venkteswara College, New Delhi; Shri A. K. Singh, *PGT (Bio)*, Kendriya Vidyalaya, Varanasi; Mrs. Chaitali Dixit, *PGT (Bio)*, Saint Anthony's School (Don Bosco), Shillong; Ms. Ishwant Kaur, *PGT (Bio)*, D. M. School, Regional Institute of Education, Bhopal; K. K. Gupta, *Reader (Rtd.)*, Zakir Hussain College, Delhi; M. M. Chaturvedi, *Professor (Zoology)*, University of Delhi, Delhi; Neelam Gupta, *PGT(Bio)*, Kendriya Vidyalaya, New Delhi; Dr. Sunil K. Shrivastava, Department of Microbiology, Shradhanand College, Delhi.

The Council is highly thankful to Hukum Singh, *Professor and Head*, DESM, NCERT, for his valuable support throughout the making of this book.

The Council also gratefully acknowledges the contribution of Deepak Kapoor, *Incharge*, Computer Station; Girish Goyal and Surender Kumar *DTP operator*; Abhimanu Mohanty, *Proof Reader*; APC office and administrative staff of DESM, NCERT.

The efforts of the Publication Department, NCERT, in bringing out this publication are also appreciated.



CONTENTS

FOREWORD		<i>iii</i>
PREFACE		v
Chapter 1	Reproduction in Organisms	1
Chapter 2	Sexual Reproduction in Flowering Plants	9
Chapter 3	Human Reproduction	17
Chapter 4	Reproductive Health	24
Chapter 5	Principle of Inheritance and Variation	29
Chapter 6	Molecular Basis of Inheritance	36
Chapter 7	Evolution	45
Chapter 8	Human Health and Diseases	51
Chapter 9	Strategies for Enhancement in Food Production	61
Chapter 10	Microbes in Human Welfare	69
Chapter 11	Biotechnology: Principles and Processes	75
Chapter 12	Biotechnology and its Applications	82
Chapter 13	Organisms and Populations	88
Chapter 14	Ecosystem	98
Chapter 15	Biodiversity and Conservation	106
Chapter 16	Environmental Issues	113



Answers to Multiple-choice Questions	121
Model Answers to Descriptive Questions	125
Model Question Paper	200

© NCERT
not to be republished

CHAPTER 1

REPRODUCTION IN ORGANISMS

MULTIPLE-CHOICE QUESTIONS

1. A few statements describing certain features of reproduction are given below:
 - i. Gametic fusion takes place
 - ii. Transfer of genetic material takes place
 - iii. Reduction division takes place
 - iv. Progeny have some resemblance with parentsSelect the options that are true for both asexual and sexual reproduction from the options given below:
(a) i and ii; (b) ii and iii; (c) ii and iv; (d) i and iii.
2. The term 'clone' cannot be applied to offspring formed by sexual reproduction because:
 - a. Offspring do not possess exact copies of parental DNA
 - b. DNA of only one parent is copied and passed on to the offspring
 - c. Offspring are formed at different times
 - d. DNA of parent and offspring are completely different.
3. *Amoeba* and Yeast reproduce asexually by fission and budding respectively, because they are:
 - a. Microscopic organisms
 - b. Heterotrophic organisms
 - c. Unicellular organisms
 - d. Uninucleate organisms.
4. A few statements with regard to sexual reproduction are given below:
 - i. Sexual reproduction does not always require two individuals
 - ii. Sexual reproduction generally involves gametic fusion
 - iii. Meiosis never occurs during sexual reproduction
 - iv. External fertilisation is a rule during sexual reproduction

Choose the correct statements from the options below:

(a) i and iv (b) i and ii (c) ii and iii (d) i and iv

5. A multicellular, filamentous alga exhibits a type of sexual life cycle in which the meiotic division occurs after the formation of zygote. The adult filament of this alga has
- haploid vegetative cells and diploid gametangia
 - diploid vegetative cells and diploid gametangia
 - diploid vegetative cells and haploid gametangia
 - haploid vegetative cells and haploid gametangia.
6. The male gametes of rice plant have 12 chromosomes in their nucleus. The chromosome number in the female gamete, zygote and the cells of the seedling will be, respectively,
- 12, 24, 12
 - 24, 12, 12
 - 12, 24, 24
 - 24, 12, 24.
7. Given below are a few statements related to external fertilization. Choose the correct statements.
- The male and female gametes are formed and released simultaneously
 - Only a few gametes are released into the medium
 - Water is the medium in a majority of organisms exhibiting external fertilization
 - Offspring formed as a result of external fertilization have better chance of survival than those formed inside an organism
- (a) iii and iv (b) i and iii (c) ii and iv (d) i and iv
8. The statements given below describe certain features that are observed in the pistil of flowers.
- Pistil may have many carpels
 - Each carpel may have more than one ovule
 - Each carpel has only one ovule
 - Pistil have only one carpel
- Choose the statements that are true from the options below:
- (a) i and ii (b) i and iii (c) ii and iv (d) iii and iv
9. Which of the following situations correctly describe the similarity between an angiosperm egg and a human egg?
- Eggs of both are formed only once in a lifetime
 - Both the angiosperm egg and human egg are stationary

- iii. Both the angiosperm egg and human egg are motile transported
 - iv. Syngamy in both results in the formation of zygote
- Choose the correct answer from the options given below:
- (a) ii and iv (b) iv only (c) iii and iv (d) i and iv
10. Appearance of vegetative propagules from the nodes of plants such as sugarcane and ginger is mainly because:
- a. Nodes are shorter than internodes
 - b. Nodes have meristematic cells
 - c. Nodes are located near the soil
 - d. Nodes have non-photosynthetic cells
11. Which of the following statements, support the view that elaborate sexual reproductive process appeared much later in the organic evolution.
- i. Lower groups of organisms have simpler body design
 - ii. Asexual reproduction is common in lower groups
 - iii. Asexual reproduction is common in higher groups of organisms
 - iv. The high incidence of sexual reproduction in angiosperms and vertebrates
- Choose the correct answer from the options given below:
- (a) i and iii; (b) i and iii (c) ii and iv (d) ii and iii
12. Offspring formed by sexual reproduction exhibit more variation than those formed by Asexual reproduction because:
- a. Sexual reproduction is a lengthy process
 - b. Gametes of parents have qualitatively different genetic composition
 - c. Genetic material comes from parents of two different species
 - d. Greater amount of DNA is involved in sexual reproduction.
13. Choose the correct statement from amongst the following:
- a. Dioecious (hermaphrodite) organisms are seen only in animals
 - b. Dioecious organisms are seen only in plants
 - c. Dioecious organisms are seen in both plants and animals
 - d. Dioecious organisms are seen only in vertebrates
14. There is no natural death in single celled organisms like *Amoeba* and bacteria because:
- a. They cannot reproduce sexually
 - b. They reproduce by binary fission
 - c. Parental body is distributed among the offspring
 - d. They are microscopic

15. There are various types of reproduction. The type of reproduction adopted by an organism depends on:
- The habitat and morphology of the organism
 - Morphology of the organism
 - Morphology and physiology of the organism
 - The organism's habitat, physiology and genetic makeup
16. Identify the incorrect statement.
- In asexual reproduction, the offspring produced are morphologically and genetically identical to the parent
 - Zoospores are sexual reproductive structures
 - In asexual reproduction, a single parent produces offspring with or without the formation of gametes
 - Conidia are asexual structures in *Penicillium*
17. Which of the following is a post-fertilisation event in flowering plants?
- Transfer of pollen grains
 - Embryo development
 - Formation of flower
 - Formation of pollen grains
18. The number of chromosomes in the shoot tip cells of a maize plant is 20. The number of chromosomes in the microspore mother cells of the same plant shall be:
- 20
 - 10
 - 40
 - 15

VERY SHORT ANSWER TYPE QUESTIONS

- Mention two inherent characteristics of *Amoeba* and yeast that enable them to reproduce asexually.
- Why do we refer to offspring formed by asexual method of reproduction as clones?
- Although potato tuber is an underground part, it is considered as a stem. Give two reasons.

4. Between an annual and a perennial plant, which one has a shorter juvenile phase? Give one reason.
5. Rearrange the following events of sexual reproduction in the sequence in which they occur in a flowering plant:
embryogenesis, fertilisation, gametogenesis, pollination.
6. The probability of fruit set in a self-pollinated bisexual flower of a plant is far greater than a dioecious plant. Explain.
7. Is the presence of large number of chromosomes in an organism a hindrance to sexual reproduction? Justify your answer by giving suitable reasons.
8. Is there a relationship between the size of an organism and its life span? Give two examples in support of your answer.
9. In the figure given below the plant bears two different types of flowers marked 'A' and 'B'. Identify the types of flowers and state the type of pollination that will occur in them.

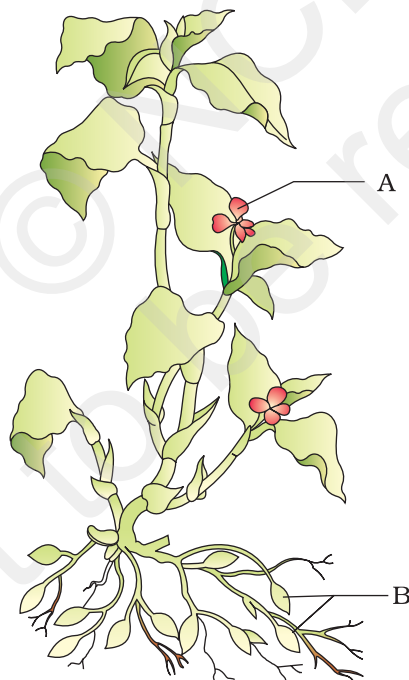

10. Give reasons as to why cell division cannot be a type of reproduction in multicellular organisms.

11. In the figure given below, mark the ovule and pericarp.

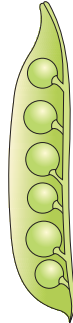

12. Why do gametes produced in large numbers in organisms exhibit external fertilisation?
13. Which of the followings are monoecious and dioecious organisms.
- Earthworm _____
 - Chara* _____
 - Marchantia* _____
 - Cockroach _____
14. Match the organisms given in Column-'A' with the vegetative propagules given in column 'B'.
- | Col. A | Col. B |
|--------------------|---------------|
| i. Bryophyllum | a) offset |
| ii. Agave | b) eyes |
| iii. Potato | c) leaf buds |
| iv. Water hyacinth | d) bulbils |
15. What do the following parts of a flower develop into after fertilisation?
- Ovary _____
 - Ovules _____

SHORT ANSWER TYPE QUESTIONS

- In haploid organisms that undergo sexual reproduction, name the stage in the life cycle when meiosis occurs. Give reasons for your answer.
- The number of taxa exhibiting asexual reproduction is drastically reduced in higher plants (angiosperms) and higher animals (vertebrates) as compared with lower groups of plants and animals. Analyse the possible reasons for this situation.

3. Honeybees produce their young ones only by sexual reproduction. In spite of this, in a colony of bees we find both haploid and diploid individuals. Name the haploid and diploid individuals in the colony and analyse the reasons behind their formation.
4. With which type of reproduction do we associate the reduction division? Analyse the reasons for it.
5. Is it possible to consider vegetative propagation observed in certain plants like *Bryophyllum*, water hyacinth, ginger etc., as a type of asexual reproduction? Give two/three reasons.
6. 'Fertilisation is not an obligatory event for fruit production in certain plants'. Explain the statement.
7. In a developing embryo, analyse the consequences if cell divisions are not followed by cell differentiation.
8. List the changes observed in an angiosperm flower subsequent to pollination and fertilisation.
9. Suggest a possible explanation why the seeds in a pea pod are arranged in a row, whereas those in tomato are scattered in the juicy pulp.
10. Draw the sketches of a zoospore and a conidium. Mention two dissimilarities between them and at least one feature common to both structures.
11. Justify the statement 'Vegetative reproduction is also a type of asexual reproduction'.

LONG ANSWER TYPE QUESTIONS

1. Enumerate the differences between asexual and sexual reproduction. Describe the types of asexual reproduction exhibited by unicellular organisms.
2. Do all the gametes formed from a parent organism have the same genetic composition (identical DNA copies of the parental genome)? Analyse the situation with the background of gametogenesis and provide or give suitable explanation.
3. Although sexual reproduction is a long drawn, energy-intensive complex form of reproduction, many groups of organisms in Kingdom Animalia and Plantae prefer this mode of reproduction. Give at least three reasons for this.
4. Differentiate between (a) oestrus and menstrual cycles; (b) ovipary and vivipary. Cite an example for each type.

5. Rose plants produce large, attractive bisexual flowers but they seldom produce fruits. On the other hand a tomato plant produces plenty of fruits though they have small flowers. Analyse the reasons for failure of fruit formation in rose.

Both these plants - rose and tomato - both selected by human beings for different characteristics, the rose for its flower and tomato for its fruit. Roses, being vegetatively propagated do not need to produce seeds.

© NCERT
not to be republished

CHAPTER 2

SEXUAL REPRODUCTION IN FLOWERING PLANTS

MULTIPLE-CHOICE QUESTIONS

1. Among the terms listed below, those that are not technically correct names for a floral whorl are:
 - i. Androecium
 - ii. Carpel
 - iii. Corolla
 - iv. Sepal(a) i and iv, (b) iii and iv (c) ii and iv (d) i and ii.
2. Embryo sac is to ovule as _____ is to an anther.
 - a. Stamen
 - b. Filament
 - c. Pollen grain
 - d. Androecium
3. In a typical complete, bisexual and hypogynous flower the arrangement of floral whorls on the thalamus from the outermost to the innermost is:
 - a. Calyx, corolla, androecium and gynoecium
 - b. Calyx, corolla, gynoecium and androecium
 - c. Gynoecium, androecium, corolla and calyx
 - d. Androecium, gynoecium, corolla and calyx
4. A dicotyledonous plant bears flowers but never produces fruits and seeds. The most probable cause for the above situation is:
 - a. Plant is dioecious and bears only pistillate flowers
 - b. Plant is dioecious and bears both pistillate and staminate flowers
 - c. Plant is monoecious
 - d. Plant is dioecious and bears only staminate flowers.

5. The outermost and innermost wall layers of microsporangium in an anther are respectively:
 - a. Endothecium and tapetum
 - b. Epidermis and endodermis
 - c. Epidermis and middle layer
 - d. Epidermis and tapetum
6. During microsporogenesis, meiosis occurs in:
 - a. Endothecium
 - b. Microspore mother cells
 - c. Microspore tetrads
 - d. Pollen grains.
7. From among the sets of terms given below, identify those that are associated with the gynoecium.
 - a. Stigma, ovule, embryo sac, placenta
 - b. Thalamus, pistil, style, ovule
 - c. Ovule, ovary, embryo sac, tapetum
 - d. Ovule, stamen, ovary, embryo sac
8. Starting from the innermost part, the correct sequence of parts in an ovule are,
 - a. egg, nucellus, embryo sac, integument
 - b. egg, embryo sac, nucellus, integument
 - c. embryo sac, nucellus, integument, egg
 - d. egg, integument, embryo sac, nucellus.
9. From the statements given below choose the option that are true for a typical female gametophyte of a flowering plant:
 - i. It is 8-nucleate and 7-celled at maturity
 - ii. It is free-nuclear during the development
 - iii. It is situated inside the integument but outside the nucellus
 - iv. It has an egg apparatus situated at the chalazal end

(a) i and iv, (b) ii and iii (c) i & ii (d) ii & iv
10. Autogamy can occur in a chasmogamous flower if:
 - a. Pollen matures before maturity of ovule
 - b. Ovules mature before maturity of pollen
 - c. Both pollen and ovules mature simultaneously
 - d. Both anther and stigma are of equal lengths.

11. Choose the correct statement from the following:
- Cleistogamous flowers always exhibit autogamy
 - Chasmogamous flowers always exhibit geitonogamy
 - Cleistogamous flowers exhibit both autogamy and geitonogamy
 - Chasmogamous flowers never exhibit autogamy
12. A particular species of plant produces light, non-sticky pollen in large numbers and its stigmas are long and feathery. These modifications facilitate pollination by:
- Insects
 - Water
 - Wind
 - Animals.
13. From among the situations given below, choose the one that prevents both autogamy and geitonogamy.
- Monoecious plant bearing unisexual flowers
 - Dioecious plant bearing only male or female flowers
 - Monoecious plant with bisexual flowers
 - Dioecious plant with bisexual flowers
14. In a fertilised embryo sac, the haploid, diploid and triploid structures are:
- Synergid, zygote and primary endosperm nucleus
 - Synergid, antipodal and polar nuclei
 - Antipodal, synergid and primary endosperm nucleus
 - Synergid, polar nuclei and zygote.
15. In an embryo sac, the cells that degenerate after fertilisation are:
- Synergids and primary endosperm cell
 - Synergids and antipodals
 - Antipodals and primary endosperm cell
 - Egg and antipodals.
16. While planning for an artificial hybridization programme involving dioecious plants, which of the following steps would not be relevant:
- Bagging of female flower
 - Dusting of pollen on stigma
 - Emasculation
 - Collection of pollen

17. In the embryos of a typical dicot and a grass, true homologous structures are:
- Coleorhiza and coleoptile
 - Coleoptile and scutellum
 - Cotyledons and scutellum
 - Hypocotyl and radicle.
18. The phenomenon observed in some plants wherein parts of the sexual apparatus is used for forming embryos without fertilisation is called:
- Parthenocarpy
 - Apomixis
 - Vegetative propagation
 - Sexual reproduction.
19. In a flower, if the megaspore mother cell forms megaspores without undergoing meiosis and if one of the megaspores develops into an embryo sac, its nuclei would be:
- Haploid
 - Diploid
 - A few haploid and a few diploid
 - With varying ploidy.
20. The phenomenon wherein, the ovary develops into a fruit without fertilisation is called:
- Parthenocarpy
 - Apomixis
 - Asexual reproduction
 - Sexual reproduction

VERY SHORT ANSWER TYPE QUESTIONS

- Name the component cells of the 'egg apparatus' in an embryo sac.
- Name the part of gynoecium that determines the compatible nature of pollen grain.
- Name the common function that cotyledons and nucellus perform.
- Complete the following flow chart

Pollen mother cell → Pollen tetrad → Pollen grain $\begin{cases} \rightarrow \text{Vegetative cell} \\ \rightarrow \text{-----} \end{cases}$

5. Indicate the stages where meiosis and mitosis occur (1, 2 or 3) in the flow chart.

Megaspore mother cell $\xrightarrow{1}$ Megaspores $\xrightarrow{2}$ Embryo sac $\xrightarrow{3}$ Egg

6. In the diagram given below, show the path of a pollen tube from the pollen on the stigma into the embryo sac. Name the components of egg apparatus.

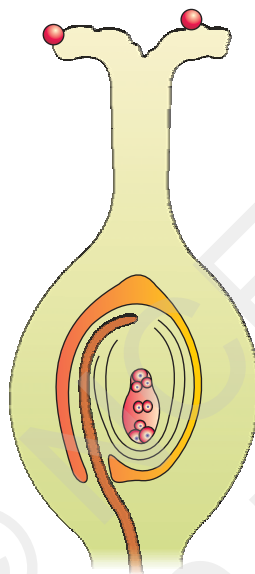

7. Name the parts of pistil which develop into fruit and seeds.
8. In case of polyembryony, if an embryo develops from the synergid and another from the nucellus which is haploid and which is diploid?
9. Can an unfertilised, apomictic embryo sac give rise to a diploid embryo? If yes, then how?
10. Which are the three cells found in a pollen grain when it is shed at the three celled stage?
11. What is self-incompatibility?
12. Name the type of pollination in self-incompatible plants.
13. Draw the diagram of a mature embryo sac and show its 8-nucleate, 7-celled nature. Show the following parts: antipodals, synergids, egg, central cell, polar nuclei.

14. Which is the triploid tissue in a fertilised ovule? How is the triploid condition achieved?
15. Are pollination and fertilisation necessary in apomixis? Give reasons.
16. Identify the type of carpel with the help of diagrams given below:

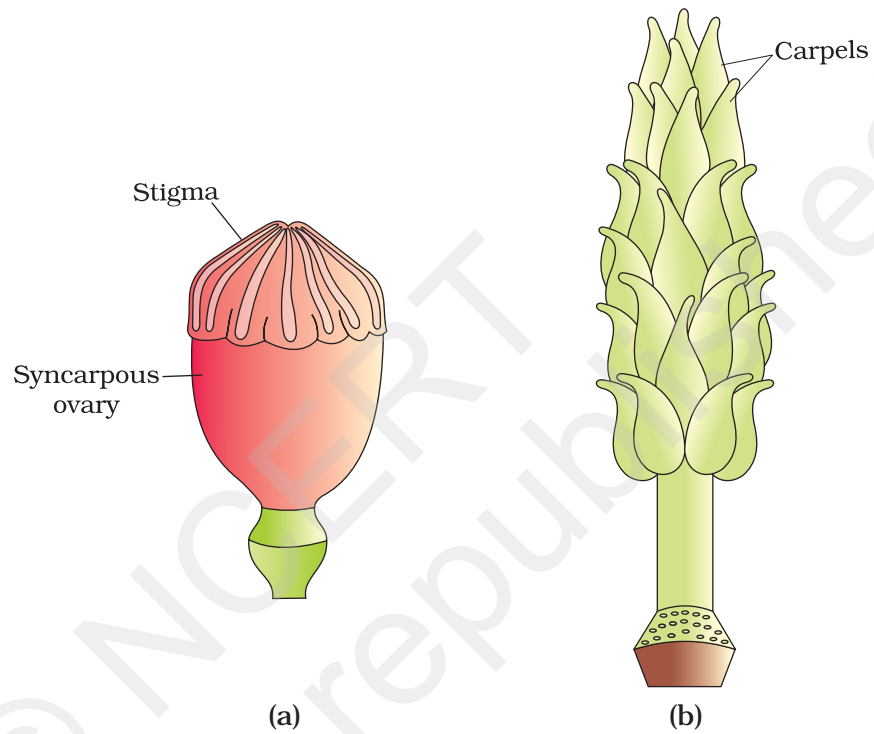

17. How is pollination carried out in water plants?
18. What is the function of the two male gametes produced by each pollen grain in angiosperms.

SHORT ANSWER TYPE QUESTIONS

1. List three strategies that a bisexual chasmogamous flower can evolve to prevent self pollination (autogamy).
2. Given below are the events that are observed in an artificial hybridization programme. Arrange them in the correct sequential order in which they are followed in the hybridisation programme.

- (a) Re-bagging (b) Selection of parents (c) Bagging (d) Dusting the pollen on stigma (e) Emasculation (f) Collection of pollen from male parent.
- Vivipary automatically limits the number of offsprings in a litter. How?
 - Does self incompatibility impose any restrictions on autogamy? Give reasons and suggest the method of pollination in such plants.
 - In the given diagram, write the names of parts shown with lines.

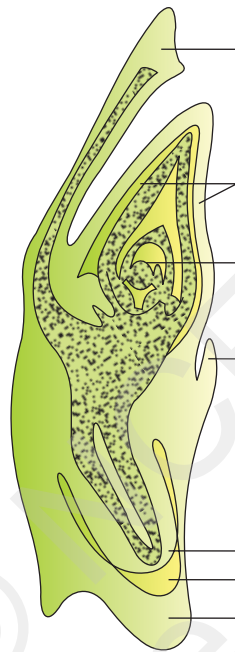

- What is polyembryony and how can it be commercially exploited?
 - Are parthenocarpy and apomixis different phenomena? Discuss their benefits.
- Hint: Yes, they are different. Parthenocarpy leads to development of seedless fruits. Apomixis leads to embryo development.
- Why does the zygote begin to divide only after the division of Primary endosperm cell (PEC)?
 - The generative cell of a two-celled pollen divides in the pollen tube but not in a three-celled pollen. Give reasons.

10. In the figure given below label the following parts: male gametes, egg cell, polar nuclei, synergid and pollen tube

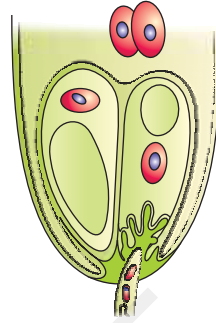

LONG ANSWER QUESTIONS

1. Starting with the zygote, draw the diagrams of the different stages of embryo development in a dicot.
2. What are the possible types of pollinations in chasmogamous flowers. Give reasons.
3. With a neat, labelled diagram, describe the parts of a mature angiosperm embryo sac. Mention the role of synergids.
4. Draw the diagram of a microsporangium and label its wall layers. Write briefly on the role of the endothecium.
5. Embryo sacs of some apomictic species appear normal but contain diploid cells. Suggest a suitable explanation for the condition.

CHAPTER 3

HUMAN REPRODUCTION

MULTIPLE-CHOICE QUESTIONS

- Choose the incorrect statement from the following:
 - In birds and mammals internal fertilisation takes place
 - Colostrum contains antibodies and nutrients
 - Polyspermy is prevented by the chemical changes in the egg surface
 - In the human female implantation occurs almost seven days after fertilisation
- Identify the wrong statement from the following:
 - High levels of estrogen triggers the ovulatory surge.
 - Orgonial cells start to proliferate and give rise to functional ova in regular cycles from puberty onwards.
 - Sperms released from seminiferous tubules are poorly motile / non-motile.
 - Progesterone level is high during the post ovulatory phase of menstrual cycle.
- Spot the odd one out from the following structures with reference to the male reproductive system:
 - Ret testis
 - Epididymis
 - Vasa efferentia
 - Isthmus
- Seminal plasma, the fluid part of semen, is contributed by.
 - Seminal vesicle
 - Prostate
 - Urethra
 - Bulbourethral gland

(a) i and ii (b) i, ii and iv (c) ii, iii and iv (d) i and iv

5. Spermiation is the process of the release of sperms from:
- Seminiferous tubules
 - Vas deferens
 - Epididymis
 - Prostate gland
6. Mature Graafian follicle is generally present in the ovary of a healthy human female around stet:
- 5 - 8 day of menstrual cycle
 - 11 - 17 day of menstrual cycle
 - 18 - 23 day of menstrual cycle
 - 24 - 28 day of menstrual cycle
7. Acrosomal reaction of the sperm occurs due to:
- Its contact with zona pellucida of the ova
 - Reactions within the uterine environment of the female
 - Reactions within the epididymal environment of the male
 - Androgens produced in the uterus
8. Which one of the following is not a male accessory gland?
- Seminal vesicle
 - Ampulla
 - Prostate
 - Bulbourethral gland
9. The immature male germ cell undergo division to produce sperms by the process of spermatogenesis. Choose the correct one with reference to above.
- Spermatogonia have 46 chromosomes and always undergo meiotic cell division
 - Primary spermatocytes divide by mitotic cell division
 - Secondary spermatocytes have 23 chromosomes and undergo second meiotic division
 - Spermatozoa are transformed into spermatids
10. Match between the following representing parts of the sperm and their functions and choose the correct option.
- | Col. A | Col. B |
|-----------------|----------------------|
| A. Head | i. Enzymes |
| B. Middle piece | ii. Sperm motility |
| C. Acrosome | iii. Energy |
| D. Tail | iv. Genetic material |

options:

- a. A-ii, B-iv, C-i, D-iii
 - b. A-iv, B-iii, C-i, D-ii
 - c. A-iv, B-i, C-ii, D-iii
 - d. A-ii, B-i, C-iii, D-iv
11. Which among the following has 23 chromosomes?
- a. Spermatogonia
 - b. Zygote
 - c. Secondary oöcyte
 - d. Oögonia
12. Match the following and choose the correct options:
- | | |
|--------------------|--|
| A. Trophoblast | i. Embedding of blastocyst in the endometrium |
| B. Cleavage | ii. Group of cells that would differentiate as embryo |
| C. Inner cell mass | iii. Outer layer of blastocyst attached to the endometrium |
| D. Implantation | iv. Mitotic division of zygote |
- Options:
- a. A-ii, B-i, C-iii, D-iv
 - b. A-iii, B-iv, C-ii, D-i
 - c. A-iii, B-i, C-ii, D-iv
 - d. A-ii, B-iv, C-iii, D-i
13. Which of the following hormones is not secreted by human placenta?
- a. hCG
 - b. Estrogens
 - c. Progesterone
 - d. LH
14. The vas deferens receives duct from the seminal vesicle and opens into urethra as:
- a. Epididymis
 - b. Ejaculatory duct
 - c. Efferent ductule
 - d. Ureter

15. Urethral meatus refers to the:
- Urinogenital duct
 - Opening of vas deferens into urethra
 - External opening of the urinogenital duct
 - Muscles surrounding the urinogenital duct
16. Morula is a developmental stage:
- Between the zygote and blastocyst
 - Between the blastocyst and gastrula
 - After the implantation
 - Between implantation and parturition
17. The membranous cover of the ovum at ovulation is:
- Corona radiata
 - Zona radiata
 - Zona pellucida
 - Chorion
18. Identify the odd one from the following:
- Labia minora
 - Fimbriae
 - Infundibulum
 - Isthmus

VERY SHORT ANSWER TYPE QUESTIONS

1. Given below are the events in human reproduction. Write them in correct sequential order.
Insemination, gametogenesis, fertilisation, parturition, gestation, implantation
2. The path of sperm transport is given below. Provide the missing steps in blank boxes.

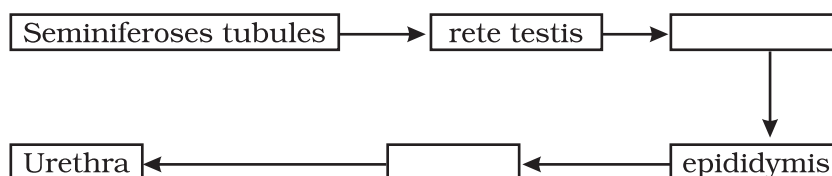

3. What is the role of cervix in the human female reproductive system?
4. Why are menstrual cycles absent during pregnancy.
5. Female reproductive organs and associated functions are given below in column A and B. Fill the blank boxes.

Column A	Column B
Ovaries	Ovulation
Oviduct	a
b	Pregnancy
Vagina	Birth

6. From where the parturition signals arise-mother or foetus? Mention the main hormone involved in parturition.
7. What is the significance of epididymis in male fertility?
8. Give the names and functions of the hormones involved in the process of spermatogenesis. Write the names of the endocrine glands from where they are released.
9. The mother germ cells are transformed into a mature follicle through series of steps. Provide the missing steps in the blank boxes.

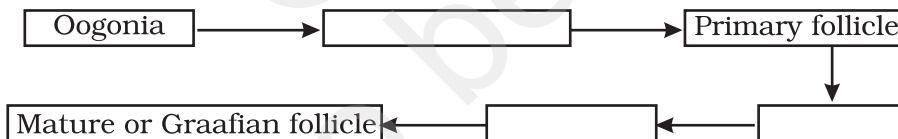

10. During reproduction, the chromosome number (2n) reduces to half (n) in the gametes and again the original number (2n) is restored in the offspring. What are the processes through which these events take place?
11. What is the difference between a primary oöcyte and a secondary oöcyte?
12. What is the significance of ampullary-isthmic junction in the female reproductive tract?
13. How does zona pellucida of ovum help in preventing polyspermy?
14. Mention the importance of LH surge during menstrual cycle.
15. Which type of cell division forms spermatids from the secondary spermatocytes?

SHORT ANSWER TYPE QUESTIONS

1. A human female experiences two major changes, menarche and menopause during her life. Mention the significance of both the events.
2.
 - a. How many spermatozoa are formed from one secondary spermatocyte?
 - b. Where does the first cleavage division of zygote take place?
3. Corpus luteum in pregnancy has a long life. However, if fertilisation does not take place, it remains active only for 10-12 days. Explain.
4. What is foetal ejection reflex? Explain how it leads to parturition?
5. Except endocrine function, what are the other functions of placenta.
6. Why doctors recommend breast feeding during initial period of infant growth?
7. What are the events that take place in the ovary and uterus during follicular phase of the menstrual cycle.
8. Given below is a flow chart showing ovarian changes during menstrual cycle. Fill in the spaces giving the name of the hormones responsible for the events shown.

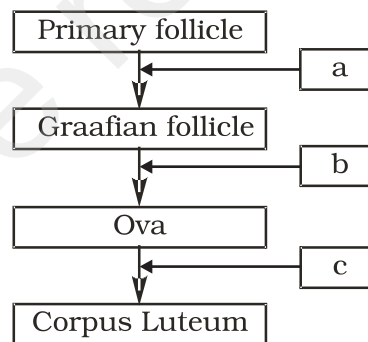

9. Give a schematic labelled diagram to represent oögenesis (without descriptions)
10. What are the changes in the oogonia during the transition of a primary follicle to Graafian follicle?

LONG ANSWER QUESTIONS

1. What role does pituitary gonadotropins play during follicular and ovulatory phases of menstrual cycle? Explain the shifts in steroidal secretions.

2. Meiotic division during oogenesis is different from that in spermatogenesis. Explain how and why?
3. The zygote passes through several developmental stages till implantation, Describe each stage briefly with suitable diagrams.
4. Draw a neat diagram of the female reproductive system and label the parts associated with the following (a) production of gamete, (b) site of fertilisation (c) site of implantation and, (d) birth canal.
5. With a suitable diagram, describe the organisation of mammary gland.

© NCERT
not to be republished

CHAPTER 4

REPRODUCTIVE HEALTH

MULTIPLE-CHOICE QUESTIONS

1. The method of directly injecting a sperm into ovum in assisted by reproductive technology is called:
 - a. GIFT
 - b. ZIFT
 - c. ICSI
 - d. ET

2. Increased IMR and decreased MMR in a population will:
 - a. Cause rapid increase in growth rate
 - b. Result in decline in growth rate
 - c. Not cause significant change in growth rate
 - d. Result in an explosive population/exp

3. Intensely lactating mothers do not generally conceive due to the:
 - a. Suppression of gonadotropins
 - b. Hyper secretion of gonadotropins
 - c. Suppression of gametic transport
 - d. Suppression of fertilisation

4. Sterilisation techniques are generally fool proof methods of contraception with least side effects. Yet, this is the last option for the couples because:
 - i. It is almost irreversible
 - ii. Of the misconception that it will reduce sexual urge/drive
 - iii. It is a surgical procedure
 - iv. Of lack of sufficient facilities in many parts of the country

Choose the correct option:
(a) i and iii (b) ii and iii (c) ii and iv (d) i, ii, iii and iv

5. A national level approach to build up a reproductively healthy society was taken up in our country in:
 - a. 1950s
 - b. 1960s
 - c. 1980s
 - d. 1990s

6. Emergency contraceptives are effective if used within:
 - a. 72 hrs of coitus
 - b. 72 hrs of ovulation
 - c. 72 hrs of menstruation
 - d. 72 hrs of implantation

7. Choose the right one among the statements given below:
 - a. IUDs are generally inserted by the user herself
 - b. IUDs increase phagocytosis reaction in the uterus
 - c. IUDs suppress gametogenesis
 - d. IUDs once inserted need not be replaced

8. Following statements are given regarding MTP. Choose the correct options given below:
 - i. MTPs are generally advised during first trimester
 - ii. MTPs are used as a contraceptive method
 - iii. MTPs are always surgical
 - iv. MTPs require the assistance of qualified medical personnel(a) ii and iii (b) ii and iii (c) i and iv (d) i and ii

9. From the sexually transmitted diseases mentioned below, identify the one which does not specifically affect the sex organs:
 - a. Syphilis
 - b. AIDS
 - c. Gonorrhoea
 - d. Genital warts

10. Condoms are one of the most popular contraceptives because of the following reasons:
 - a. These are effective barriers for insemination
 - b. They do not interfere with coital act
 - c. These help in reducing the risk of STDs
 - d. All of the above

11. Choose the correct statement regarding the ZIFT procedure:
- Ova collected from a female donor are transferred to the fallopian tube to facilitate zygote formation.
 - Zygote is collected from a female donor and transferred to the fallopian tube
 - Zygote is collected from a female donor and transferred to the uterus
 - Ova collected from a female donor and transferred to the uterus
12. The correct surgical procedure as a contraceptive method is:
- Ovariectomy
 - Hysterectomy
 - Vasectomy
 - Castration
13. Diaphragms are contraceptive devices used by the females. Choose the correct option from the statements given below:
- They are introduced into the uterus
 - They are placed to cover the cervical region
 - They act as physical barriers for sperm entry
 - They act as spermicidal agents
- (a) i and ii, (b) i and iii, (c) ii and iii, (d) iii & iv

VERY SHORT ANSWER TYPE QUESTIONS

- Reproductive health refers only to healthy reproductive functions. Comment.
- Comment on the Reproductive and Child Health Care programme of the government to improve the reproductive health of the people.
- The present population growth rate in India is alarming. Suggest ways to check it.
- STDs can be considered as self-invited diseases. Comment.
- Suggest the reproduction-related aspects in which counselling should be provided at the school level.
- Mention the primary aim of the "Assisted Reproductive Technology" (ART) programme.
- What is the significance of progesterone-estrogen combination as a contraceptive measure?

8. Strict conditions are to be followed in medical termination of pregnancy (MTP) procedures. Mention two reasons.
9. Males in whom testes fail to descend to the scrotum are generally infertile. Why?
10. Mention two advantages of lactational amenorrhea as a contraceptive method.

SHORT ANSWER TYPE QUESTIONS

1. Suggest some important steps that you would recommend to be taken to improve the reproductive health standards in India.
2. The procedure of GIFT involves the transfer of female gamete to the fallopian tube. Can gametes be transferred to the uterus to achieve the same result? Explain.
3. Copper ions-releasing IUDs are more efficient than non-medicated methods. Why?
4. What are the probable factors that contributed to population explosion in India?
5. Briefly explain IVF and ET. What are the conditions in which these methods are advised?
6. What are the advantages of natural methods of contraception over artificial methods?
7. What are the conditions in which medical termination of pregnancy is advised?
8. Comment on the essential features required for an ideal contraceptive.
9. All reproductive tract infections RTIs are STDs, but all STDs are not RTIs. Justify with example.

LONG ANSWER TYPE QUESTIONS

1. What are the Assisted Reproductive Techniques practised to help infertile couples? Describe any three techniques.
2. Discuss the mode of action and advantages/disadvantages of hormonal contraceptives.
3. STDs are a threat to reproductive health. Describe any two such diseases and suggest preventive measures.

4. Do you justify the statutory ban on aminocentesis in our country? Give reasons.
5. Enumerate and describe any five reasons for introducing sex education to school-going children.

© NCERT
not to be republished

CHAPTER 5

PRINCIPLE OF INHERITANCE AND VARIATION

MULTIPLE-CHOICE QUESTIONS

- All genes located on the same chromosome:
 - Form different groups depending upon their relative distance
 - Form one linkage group
 - Will not form any linkage groups
 - Form interactive groups that affect the phenotype
- Conditions of a karyotype $2n \pm 1$ and $2n \pm 2$ are called:
 - Aneuploidy
 - Polyploidy
 - Allopolyploidy
 - Monosomy
- Distance between the genes and percentage of recombination shows:
 - a direct relationship
 - an inverse relationship
 - a parallel relationship
 - no relationship
- If a genetic disease is transferred from a phenotypically normal but carrier female to only some of the male progeny, the disease is:
 - Autosomal dominant
 - Autosomal recessive
 - Sex-linked dominant
 - Sex-linked recessive

5. In sickle cell anaemia glutamic acid is replaced by valine. Which one of the following triplets codes for valine?
 - a. G G G
 - b. A A G
 - c. G A A
 - d. G U G

6. Person having genotype $I^A I^B$ would show the blood group as AB. This is because of:
 - a. Pleiotropy
 - b. Co-dominance
 - c. Segregation
 - d. Incomplete dominance

7. ZZ / ZW type of sex determination is seen in:
 - a. Platypus
 - b. Snails
 - c. Cockroach
 - d. Peacock

8. A cross between two tall plants resulted in offspring having few dwarf plants. What would be the genotypes of both the parents?
 - a. TT and Tt
 - b. Tt and Tt
 - c. TT and TT
 - d. Tt and tt

9. In a dihybrid cross, if you get 9:3:3:1 ratio it denotes that:
 - a. The alleles of two genes are interacting with each other
 - b. It is a multigenic inheritance
 - c. It is a case of multiple allelism
 - d. The alleles of two genes are segregating independently.

10. Which of the following will not result in variations among siblings?
 - a. Independent assortment of genes
 - b. Crossing over
 - c. Linkage
 - d. Mutation

11. Mendel's Law of independent assortment holds good for genes situated on the:
 - a. non-homologous chromosomes
 - b. homologous chromosomes
 - c. extra nuclear genetic element
 - d. same chromosome

12. Occasionally, a single gene may express more than one effect. The phenomenon is called:
 - a. multiple allelism
 - b. mosaicism
 - c. pleiotropy
 - d. polygeny

13. In a certain taxon of insects some have 17 chromosomes and the others have 18 chromosomes. The 17 and 18 chromosome-bearing organisms are:
 - a. males and females, respectively
 - b. females and males, respectively
 - c. all males
 - d. all females

14. The inheritance pattern of a gene over generations among humans is studied by the pedigree analysis. Character studied in the pedigree analysis is equivalent to:
 - a. quantitative trait
 - b. Mendelian trait
 - c. polygenic trait
 - d. maternal trait

15. It is said that Mendel proposed that the factor controlling any character is discrete and independent. This proposition was based on the:
 - a. results of F_3 generation of a cross.
 - b. observations that the offspring of a cross made between the plants having two contrasting characters shows only one character without any blending.
 - c. self pollination of F_1 offsprings
 - d. cross pollination of parental generations

16. Two genes 'A' and 'B' are linked. In a dihybrid cross involving these two genes, the F_1 heterozygote is crossed with homozygous recessive parental type (aa bb). What would be the ratio of offspring in the next generation?
- 1 : 1 : 1 : 1
 - 9 : 3 : 3 : 1
 - 3 : 1
 - 1 : 1
17. In the F_2 generation of a Mendelian dihybrid cross the number of phenotypes and genotypes are:
- phenotypes - 4; genotypes - 16
 - phenotypes - 9; genotypes - 4
 - phenotypes - 4; genotypes - 8
 - phenotypes - 4; genotypes - 9
18. Mother and father of a person with 'O' blood group have 'A' and 'B' blood group respectively. What would be the genotype of both mother and father?
- Mother is homozygous for 'A' blood group and father is heterozygous for 'B'
 - Mother is heterozygous for 'A' blood group and father is homozygous for 'B'
 - Both mother and father are heterozygous for 'A' and 'B' blood group, respectively
 - Both mother and father are homozygous for 'A' and 'B' blood group, respectively

VERY SHORT ANSWER TYPE QUESTIONS

1. What is the cross between the progeny of F_1 and the homozygous recessive parent called? How is it useful?
2. Do you think Mendel's laws of inheritance would have been different if the characters that he chose were located on the same chromosome.
3. Enlist the steps of controlled cross pollination. Would emasculation be needed in a cucurbit plant? Give reasons for your answer.
4. A person has to perform crosses for the purpose of studying inheritance of a few traits / characters. What should be the criteria for selecting the organisms?

5. The pedigree chart given below shows a particular trait which is absent in parents but present in the next generation irrespective of sexes. Draw your conclusion on the basis of the pedigree.

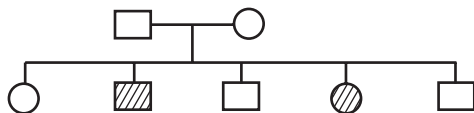

6. In order to obtain the F_1 generation Mendel pollinated a pure-breeding tall plant with a pure breeding dwarf plant. But for getting the F_2 generation, he simply self-pollinated the tall F_1 plants. Why?
7. "Genes contain the information that is required to express a particular trait." Explain.
8. How are alleles of particular gene differ from each other? Explain its significance.
9. In a monohybrid cross of plants with red and white flowered plants, Mendel got only red flowered plants. On self-pollinating these F_1 plants got both red and white flowered plants in 3:1 ratio. Explain the basis of using RR and rr symbols to represent the genotype of plants of parental generation.
10. For the expression of traits genes provide only the potentiality and the environment provides the opportunity. Comment on the veracity of the statement.
11. A, B, D are three independently assorting genes with their recessive alleles a, b, d, respectively. A cross was made between individuals of Aa bb DD genotype with aa bb dd. Find out the type of genotypes of the offspring produced.
12. In our society a woman is often blamed for not bearing male child. Do you think it is right? Justify.
13. Discuss the genetic basis of wrinkled phenotype of pea seed.
14. Even if a character shows multiple allelism, an individual will only have two alleles for that character. Why?
15. How does a mutagen induce mutation? Explain with example.

SHORT ANSWER TYPE QUESTIONS

1. In a Mendelian monohybrid cross, the F_2 generation shows identical genotypic and phenotypic ratios. What does it tell us about the nature of alleles involved? Justify your answer.

2. Can a child have blood group O if his parents have blood group 'A' and 'B'. Explain.
3. What is Down's syndrome? Give its symptoms and cause. Why is it that the chances of having a child with Down's syndrome increases if the age of the mother exceeds forty years?
4. How was it concluded that genes are located on chromosomes?
5. A plant with red flowers was crossed with another plant with yellow flowers. If F_1 showed all flowers orange in colour, explain the inheritance.
6. What are the characteristic features of a true-breeding line?
7. In peas, tallness is dominant over dwarfness, and red colour of flowers is dominant over the white colour. When a tall plant bearing red flowers was pollinated with a dwarf plant bearing white flowers, the different phenotypic groups were obtained in the progeny in numbers mentioned against them:

Tall, Red = 138

Tall, White = 132

Dwarf, Red = 136

Dwarf, White = 128

Mention the genotypes of the two parents and of the four offspring types.

8. Why is the frequency of red-green colour blindness is many times higher in males than that in the females?
9. If a father and son are both defective in red-green colour vision, is it likely that the son inherited the trait from his father? Comment.
10. Discuss why *Drosophila* has been used extensively for genetical studies.
11. How do genes and chromosomes share similarity from the point of view of genetical studies?
12. What is recombination? Discuss the applications of recombination from the point of view of genetic engineering.
13. What is artificial selection? Do you think it affects the process of natural selection? How?
14. With the help of an example differentiate between incomplete dominance and co-dominance.
15. It is said, that the harmful alleles get eliminated from population over a period of time, yet sickle cell anaemia is persisting in human population. Why?

LONG ANSWER TYPE QUESTIONS

1. In a plant tallness is dominant over dwarfness and red flower is dominant over white. Starting with the parents work out a dihybrid cross. What is standard dihybrid ratio? Do you think the values would deviate if the two genes in question are interacting with each other?
2.
 - a. In humans, males are heterogametic and females are homogametic. Explain. Are there any examples where males are homogametic and females heterogametic?
 - b. Also describe as to, who determines the sex of an unborn child? Mention whether temperature has a role in sex determination.
3. A normal visioned woman, whose father is colour blind, marries a normal visioned man. What would be probability of her sons and daughters to be colour blind? Explain with the help of a pedigree chart.
4. Discuss in detail the contributions of Morgan and Sturvant in the area of genetics.
5. Define aneuploidy. How is it different from polyploidy? Describe the individuals having following chromosomal abnormalities.
 - a. Trisomy of 21st Chromosome
 - b. XXY
 - c. XO

CHAPTER 6

MOLECULAR BASIS OF INHERITANCE

MULTIPLE-CHOICE QUESTIONS

- In a DNA strand the nucleotides are linked together by:
 - glycosidic bonds
 - phosphodiester bonds
 - peptide bonds
 - hydrogen bonds
- A nucleoside differs from a nucleotide. It lacks the:
 - base
 - sugar
 - phosphate group
 - hydroxyl group
- Both deoxyribose and ribose belong to a class of sugars called:
 - trioses
 - hexoses
 - pentoses
 - polysaccharides
- The fact that a purine base always paired through hydrogen bonds with a pyrimidine base leads to, in the DNA double helix:
 - the antiparallel nature
 - the semiconservative nature
 - uniform width throughout DNA
 - uniform length in all DNA
- The net electric charge on DNA and histones is:
 - both positive
 - both negative
 - negative and positive, respectively
 - zero

6. The promoter site and the terminator site for transcription are located at:
 - a. 3' (downstream) end and 5' (upstream) end, respectively of the transcription unit
 - b. 5' (upstream) end and 3' (downstream) end, respectively of the transcription unit
 - c. the 5' (upstream) end
 - d. the 3' (downstream) end
7. Which of the following statements is the most appropriate for sickle cell anaemia?
 - a. It cannot be treated with iron supplements
 - b. It is a molecular disease
 - c. It confers resistance to acquiring malaria
 - d. All of the above
8. One of the following is true with respect to AUG
 - a. It codes for methionine only
 - b. It is also an initiation codon
 - c. It codes for methionine in both prokaryotes and eukaryotes
 - d. All of the above
9. The first genetic material could be:
 - a. protein
 - b. carbohydrates
 - c. DNA
 - d. RNA
10. With regard to mature mRNA in eukaryotes:
 - a. exons and introns do not appear in the mature RNA
 - b. exons appear but introns do not appear in the mature RNA
 - c. introns appear but exons do not appear in the mature RNA
 - d. both exons and introns appear in the mature RNA
11. The human chromosome with the highest and least number of genes in them are respectively:
 - a. Chromosome 21 and Y
 - b. Chromosome 1 and X
 - c. Chromosome 1 and Y
 - d. Chromosome X and Y

12. Who amongst the following scientists had no contribution in the development of the double helix model for the structure of DNA?
- Rosalind Franklin
 - Maurice Wilkins
 - Erwin Chargaff
 - Meselson and Stahl
13. DNA is a polymer of nucleotides which are linked to each other by 3'-5' phosphodiester bond. To prevent polymerisation of nucleotides, which of the following modifications would you choose?
- Replace purine with pyrimidines
 - Remove/Replace 3' OH group in deoxy ribose
 - Remove/Replace 2' OH group with some other group in deoxy ribose
 - Both 'B' and 'C'
14. Discontinuous synthesis of DNA occurs in one strand, because:
- DNA molecule being synthesised is very long
 - DNA dependent DNA polymerase catalyses polymerisation only in one direction (5' → 3')
 - it is a more efficient process
 - DNA ligase has to have a role
15. Which of the following steps in transcription is catalysed by RNA polymerase?
- Initiation
 - Elongation
 - Termination
 - All of the above
16. Control of gene expression takes place at the level of:
- DNA-replication
 - Transcription
 - Translation
 - None of the above
17. Regulatory proteins are the accessory proteins that interact with RNA polymerase and affect its role in transcription. Which of the following statements is correct about regulatory protein?
- They only increase expression
 - They only decrease expression
 - They interact with RNA polymerase but do not affect the expression
 - They can act both as activators and as repressors

18. Which was the last human chromosome to be completely sequenced:
- Chromosome 1
 - Chromosome 11
 - Chromosome 21
 - Chromosome x
19. Which of the following are the functions of RNA?
- It is a carrier of genetic information from DNA to ribosomes synthesising polypeptides.
 - It carries amino acids to ribosomes.
 - It is a constituent component of ribosomes.
 - All of the above.
20. While analysing the DNA of an organism a total number of 5386 nucleotides were found out of which the proportion of different bases were: Adenine = 29%, Guanine = 17%, Cytosine = 32%, Thymine = 17%. Considering the Chargaff's rule it can be concluded that:
- it is a double stranded circular DNA
 - It is single stranded DNA
 - It is a double stranded linear DNA
 - No conclusion can be drawn
21. In some viruses, DNA is synthesised by using RNA as template. Such a DNA is called:
- A-DNA
 - B-DNA
 - c DNA
 - r DNA
22. If Meselson and Stahl's experiment is continued for four generations in bacteria, the ratio of $^{15}\text{N}/^{15}\text{N}$: $^{15}\text{N}/^{14}\text{N}$: $^{14}\text{N}/^{14}\text{N}$ containing DNA in the fourth generation would be:
- 1:1:0
 - 1:4:0
 - 0:1:3
 - 0:1:7
23. If the sequence of nitrogen bases of the coding strand of DNA in a transcription unit is:
- 5' - A T G A A T G - 3',
- the sequence of bases in its RNA transcript would be;
- 5' - A U G A A U G - 3'

- b. 5' - U A C U U A C - 3'
c. 5' - C A U U C A U - 3'
d. 5' - G U A A G U A - 3'
24. The RNA polymerase holoenzyme transcribes:
a. the promoter, structural gene and the terminator region
b. the promoter, and the
c. the structural gene and the terminator regions
d. the structural gene only.
25. If the base sequence of a codon in mRNA is 5'-AUG-3', the sequence of tRNA pairing with it must be:
a. 5' - UAC - 3'
b. 5' - CAU - 3'
c. 5' - AUG - 3'
d. 5' - GUA - 3'
26. The amino acid attaches to the tRNA at its:
a. 5' - end
b. 3' - end
c. Anti codon site
d. DHU loop
27. To initiate translation, the mRNA first binds to:
a. The smaller ribosomal sub-unit,
b. The larger ribosomal sub-unit
c. The whole ribosome
d. No such specificity exists.
28. In *E.coli*, the lac operon gets switched on when:
a. lactose is present and it binds to the repressor
b. repressor binds to operator
c. RNA polymerase binds to the operator
d. lactose is present and it binds to RNA polymerase

VERY SHORT ANSWER TYPE QUESTIONS

1. What is the function of histones in DNA packaging?
2. Distinguish between heterochromatin and euchromatin. Which of the two is transcriptionally active?

3. The enzyme DNA polymerase in *E. coli* is a DNA dependent polymerase and also has the ability to proof-read the DNA strand being synthesised. Explain. Discuss the dual polymerase.
4. What is the cause of discontinuous synthesis of DNA on one of the parental strands of DNA? What happens to these short stretches of synthesised DNA?
5. Given below is the sequence of coding strand of DNA in a transcription unit
3' A A T G C A G C T A T T A G G - 5'
write the sequence of
 - a) its complementary strand
 - b) the mRNA
6. What is DNA polymorphism? Why is it important to study it?
7. Based on your understanding of genetic code, explain the formation of any abnormal hemoglobin molecule. What are the known consequences of such a change?
8. Sometimes cattle or even human beings give birth to their young ones that are having extremely different sets of organs like limbs/position of eye(s) etc. Comment.
9. In a nucleus, the number of ribonucleoside triphosphates is 10 times the number of deoxy x10 ribonucleoside triphosphates, but only deoxy ribonucleotides are added during the DNA replication. Suggest a mechanism.
10. Name a few enzymes involved in DNA replication other than DNA polymerase and ligase. Name the key functions for each of them.
11. Name any three viruses which have RNA as the genetic material.

SHORT ANSWER TYPE QUESTIONS

1. Define transformation in Griffith's experiment. Discuss how it helps in the identification of DNA as the genetic material.
2. Who revealed biochemical nature of the transforming principle? How was it done?
3. Discuss the significance of heavy isotope of nitrogen in the Meselson and Stahl's experiment.

4. Define a cistron. Giving examples differentiate between monocistronic and polyeistronic transcription unit.
5. Give any six features of the human genome.
6. During DNA replication, why is it that the entire molecule does not open in one go? Explain replication fork. What are the two functions that the monomers (d NTPs) play?
7. Retroviruses do not follow central Dogma. Comment.
8. In an experiment, DNA is treated with a compound which tends to place itself amongst the stacks of nitrogenous base pairs. As a result of this, the distance between two consecutive base increases. from 0.34nm to 0.44 nm calculate the length of DNA double helix (which has 2×10^9 bp) in the presence of saturating amount of this compound.
9. What would happen if histones were to be mutated and made rich in acidic amino acids such as aspartic acid and glutamic acid in place of basic amino acids such as lysine and arginine?
10. Recall the experiments done by Frederick Griffith, Avery, MacLeod and McCarty, where DNA was speculated to be the genetic material. If RNA, instead of DNA was the genetic material, would the heat killed strain of Pneumococcus have transformed the R-strain into virulent strain? Explain.
11. You are repeating the Hershey-Chase experiment and are provided with two isotopes: ^{32}P and ^{15}N (in place of ^{35}S in the original experiment). How do you expect your results to be different?
12. There is only one possible sequence of amino acids when deduced from a given nucleotides. But multiple nucleotides sequence can be deduced from a single amino acid sequence. Explain this phenomena.
13. A single base mutation in a gene may not 'always' result in loss or gain of function. Do you think the statement is correct? Defend your answer.
14. A low level of expression of lac operon occurs at all the time. Can you explain the logic behind this phenomena.
15. How has the sequencing of human genome opened new windows for treatment of various genetic disorders. Discuss amongst your classmates.
16. The total number of genes in humans is far less ($< 25,000$) than the previous estimate (upto 1,40,000 gene). Comment.
17. Now, sequencing of total genomes getting is getting less expensive day by the day. Soon it may be affordable for a common man to get his genome sequenced. What in your opinion could be the advantage and disadvantage of this development?

18. Would it be appropriate to use DNA probes such as VNTR in DNA finger printing of a bacteriophage?
19. During in vitro synthesis of DNA, a researcher used 2', 3' - dideoxy cytidine triphosphate as raw nucleotide in place of 2'-deoxy cytidine. What would be the consequence?
20. What background information did Watson and Crick have made available for developing a model of DNA? What was their contribution?
21. What are the functions of (i) methylated guanosine cap, (ii) poly-A "tail" in a mature mRNA?
22. Do you think that the alternate splicing of exons may enable a structural gene to code for several isoproteins from one and the same gene? If yes, how? If not, why so?
23. Comment on the utility of variability in number of tandem repeats during DNA finger printing.

LONG ANSWER TYPE QUESTIONS

1. Give an account of Hershey and Chase experiment. What did it conclusively prove? If both DNA and proteins contained phosphorus and sulphur do you think the result would have been the same?
2. During the course of evolution why DNA was chosen over RNA as genetic material? Give reasons by first discussing the desired criteria in a molecule that can act as genetic material and in the light of biochemical differences between DNA and RNA.
3. Give an account of post transcriptional modifications of a eukaryotic mRNA.
4. Discuss the process of translation in detail.
5. Define an operon. giving an example, explain an Inducible operon.
6. 'There is a paternity dispute for a child'. Which technique can solve the problem. Discuss the principle involved.
7. Give an account of the methods used in sequencing the human genome.
8. List the various markers that are used in DNA finger printing.
9. Replication was allowed to take place in the presence of radioactive deoxynucleotides precursors in *E.coli* that was a mutant for DNA ligase. Newly synthesised radioactive DNA was purified and strands

were separated by denaturation. These were centrifuged using density gradient centrifugation. Which of the following would be a correct result?

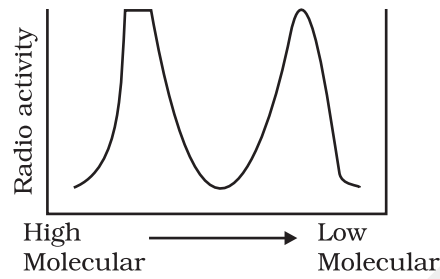

(a)

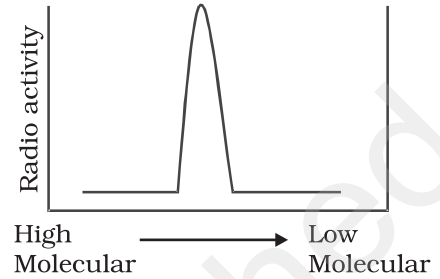

(b)

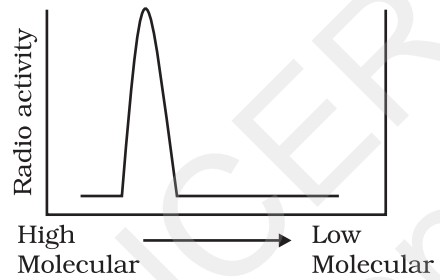

(c)

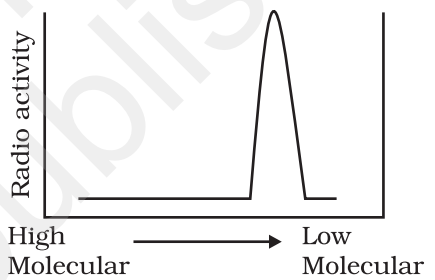

(d)

CHAPTER 7

EVOLUTION

MULTIPLE CHOICE QUESTIONS

- Which of the following is used as an atmospheric pollution indicator?
 - Lepidoptera
 - Lichens
 - Lycopersicon*
 - Lycopodium*
- The theory of spontaneous generation stated that:
 - life arose from living forms only
 - life can arise from both living and non-living
 - life can arise from non-living things only.
 - life arises spontaneously, neither from living nor from the non-living.
- Animal husbandry and plant breeding programmes are the examples of:
 - reverse evolution
 - artificial selection
 - mutation
 - natural selection
- Palaentological evidences for evolution refer to the:
 - development of embryo
 - homologous organs
 - fossils
 - analogous organs.
- The bones of forelimbs of whale, bat, cheetah and man are similar in structure, because:
 - one organism has given rise to another
 - they share a common ancestor

- c. they perform the same function
 - d. they have biochemical similarities
6. Analogous organs arise due to:
- a. divergent evolution
 - b. artificial selection
 - c. genetic drift
 - d. convergent evolution
7. $(p+q)^2 = P^2 + 2pq + q^2 = 1$ represents an equation used in:
- a. population genetics
 - b. mendelian genetics
 - c. biometrics
 - d. molecular genetics
8. Appearance of antibiotic-resistant bacteria is an example of:
- a. adaptive radiation
 - b. transduction
 - c. pre-existing variation in the population
 - d. divergent evolution
9. Evolution of life shows that life forms had a trend of moving from:
- a. land to water
 - b. dryland to wet land
 - c. fresh water to sea water
 - d. water to land
10. Viviparity is considered to be more evolved because:
- a. the young ones are left on their own
 - b. the young ones are protected by a thick shell
 - c. the young ones are protected inside the mother's body and are looked after they are born leading to more chances of survival
 - d. the embryo takes a long time to develop
11. Fossils are generally found in:
- a. Sedimentary rocks
 - b. Igneous rocks
 - c. Metamorphic rocks
 - d. Any type of rock

12. For the MN-blood group system, the frequencies of M and N alleles are 0.7 and 0.3, respectively. The expected frequency of MN-blood group bearing organisms is likely to be
- 42%
 - 49%
 - 9%
 - 58%
13. Which type of selection is industrial melanism observed in moth, *Biston bitularia*:
- Stabilising
 - Directional
 - Disruptive
 - Artificial
14. The most accepted line of descent in human evolution is:
- Australopithecus → Ramapithecus → Homo sapiens → homo habilis
 - Homo erectus → Homo habilis → Homo sapiens
 - Ramapithecus → Homo habilis → Homo erectus → Homo sapiens
 - Australopithecus → Ramapithecus → Homo erectus → Homo habilis → Homo sapiens.
15. Which of the following is an example for link species?
- Lobe fish
 - Dodo bird
 - Sea weed
 - Tyrannosaurus rex
16. Match the scientists listed under column 'A' with ideas listed column 'B'.
- | Column 1 | Column 2 |
|--------------|-----------------------------------|
| i. Darwin | M. abiogenesis |
| ii. Oparin | N. use and disuse of organs |
| iii. Lamarck | O. continental drift theory |
| iv. Wagner | P. evolution by natural selection |
- i-M; ii-P; iii-N; iv-O
 - i-P; ii-M; iii-N; iv-O
 - i-N; ii-P; iii-O; iv-M
 - i-p; ii-O; iii-N; iv-M

17. In 1953 S. L. Miller created primitive earth conditions in the laboratory and gave experimental evidence for origin of first form of life from pre-existing non-living organic molecules. The primitive earth conditions created include:
- low temperature, volcanic storms, atmosphere rich in oxygen
 - low temperature, volcanic storms, reducing atmosphere
 - high temperature, volcanic storms, non-reducing atmosphere
 - high temperature, volcanic storms, reducing atmosphere containing CH_4 , NH_3 etc.
18. Variations during mutations of meiotic recombinations are:
- random and directionless
 - random and directional
 - random and small
 - random, small and directional

VERY SHORT ANSWER TYPE QUESTIONS

- What were the characteristics of life forms that had been fossilised?
- Did aquatic life forms get fossilised? If, yes where do we come across such fossils?
- What are we referring to? When we say 'simple organisms' or 'complex organisms'.
- How do we compute the age of a living tree?
- Give an example for convergent evolution and identify the features towards which they are converging.
- How do we compute the age of a fossil?
- What is the most important pre-condition for adaptive radiation?
- How do we compute the age of a rock?
- When we talk of functional macromolecules (e.g. proteins as enzymes, hormones, receptors, antibodies etc), towards what are they evolving?
- In a certain population, the frequency of three genotypes is as follows:

Genotypes:	BB	Bb	bb
frequency:	22%	62%	16%

What is the likely frequency of B and b alleles?

11. Among the five factors that are known to affect Hardy-Weinberg equilibrium, three factors are gene flow, genetic drift and genetic recombination. What are the other two factors?
12. What is founder effect?
13. Who among the *Dryopithecus* and *Ramapithecus* was more man-like?
14. By what Latin name the first hominid was known?
15. Among *Ramapithecus*, *Australopithecines* and *Homo habilis* - who probably did not eat meat?

SHORT ANSWER TYPE QUESTIONS

1. Louis Pasteur's experiments, if you recall, proved that life can arise from only pre-existing life. Can we correct this as life evolves from pre-existent life or otherwise we will never answer the question as to how the first forms of life arose? Comment.
2. The scientists believe that evolution is gradual. But extinction, part of evolutionary story, are 'sudden' and 'abrupt' and also group-specific. Comment whether a natural disaster can be the cause for extinction of species.
3. Why is nascent oxygen supported to be toxic to aerobic life forms?
4. While creation and presence of variation is directionless, natural selection is directional as it is in the context of adaptation. Comment.
5. The evolutionary story of moths in England during industrialisation reveals, that 'evolution is apparently reversible'. Clarify this statement.
6. Comment on the statement that "evolution and natural selection are end result or consequence of some other processes but themselves are not processes".
7. State and explain any three factors affecting allele frequency in populations.
8. Gene flow occurs through generations. Gene flow can occur across language barriers in humans. If we have a technique of measuring specific allele frequencies in different population of the world, can we not predict human migratory patterns in pre-history and history? Do you agree or disagree? Provide explanation to your answer.

9. How do you express the meaning of words like race, breed, cultivars or variety?
10. When we say "survival of the fittest", does it mean that
 - a. those which are fit only survive, or
 - b. those that survive are called fit?Comment.
11. Enumerate three most characteristic criteria for designating a Mendelian population.
12. "Migration may enhance or blurr the effects of selection". Comment.

LONG ANSWER TYPE QUESTIONS

1. Name the law that states that the sum of allelic frequencies in a population remains constant. What are the five factors that influence these values?
2. Explain divergent evolution in detail. What is the driving force behind it?
3. You have studied the story of Pepper moths in England. Had the industries been removed, what impact could it have on the moth population? Discuss.
4. What are the key concepts in the evolution theory of Darwin?
5. Two organisms occupying a particular geographical area (say desert) show similar adaptive strategies. Taking examples, describe the phenomenon.
6. We are told that evolution is a continuing phenomenon for all living things. Are humans also evolving? Justify your answer.
7. Had Darwin been aware of Mendel's work, would he been able to explain the origin of variations. Discuss.

CHAPTER 8

HUMAN HEALTH AND DISEASES

MULTIPLE-CHOICE QUESTIONS

- The term 'Health' is defined in many ways. The most accurate definition of the health would be:
 - health is the state of body and mind in a balanced condition
 - health is the reflection of a smiling face
 - health is a state of complete physical, mental and social well-being
 - health is the symbol of economic prosperity.
- The organisms which cause diseases in plants and animals are called:
 - Pathogens
 - Vectors
 - Insects
 - Worms
- The chemical test that is used for diagnosis of typhoid is:
 - ELISA-Test
 - ESR - Test
 - PCR - Test
 - Widal-Test
- Diseases are broadly grouped into infectious and non-infectious diseases. In the list given below, identify the infectious diseases.
 - Cancer
 - Influenza
 - Allergy
 - Small pox

(a) i and ii (b) ii and iii (c) iii and iv (d) ii and iv
- The sporozoites that cause infection when a female *Anopheles* mosquito bites a human being are formed in:
 - Liver of human
 - RBCs of mosquito

- c. salivary glands of mosquito
 - d. intestine of human
6. The disease *chikunguniya* is transmitted by:
- a. house flies
 - b. *Aedes* mosquitoes
 - c. cockroach
 - d. female *Anopheles*
7. Many diseases can be diagnosed by observing the symptoms in the patient. Which group of symptoms are indicative of pneumonia?
- a. Difficulty in respiration, fever, chills, cough, headache
 - b. Constipation, abdominal pain, cramps, blood clots
 - c. Nasal congestion and discharge, cough, sorethroat, headache
 - d. High fever, weakness, stomach pain, loss of appetite and constipation
8. The genes causing cancer are:
- a. structural genes
 - b. expressor genes
 - c. oncogenes
 - d. regulatory genes
9. In malignant tumors, the cells proliferate, grow rapidly and move to other parts of the body to form new tumors. This stage of disease is called:
- a. metagenesis
 - b. metastasis
 - c. teratogenesis
 - d. mitosis
10. When an apparently healthy person is diagnosed as unhealthy by a psychiatrist, the reason could be that:
- a. the patient was not efficient at his work
 - b. the patient was not economically prosperous
 - c. the patient shows behavioural and social maladjustment
 - d. he does not take interest in sports
11. Which of the following are the reason(s) for Rheumatoid arthritis? Choose the correct option.
- i. Lymphocytes become more active

- ii. Body attacks self cells
 - iii. More antibodies are produced in the body
 - iv. The ability to differentiate pathogens or foreign molecules from self cells is lost
- (a) i and ii (b) ii and iv (c) iii and iv (d) i and iii
12. AIDS is caused by HIV. Among the following, which one is not a mode of transmission of HIV?
- a. Transfusion of contaminated blood
 - b. Sharing the infected needles
 - c. Shaking hands with infected persons
 - d. Sexual contact with infected persons
13. 'Smack' is a drug obtained from the:
- a. latex of *Papaver somniferum*
 - b. leaves of *Cannabis sativa*
 - c. flowers of *Datura*
 - d. fruits of *Erythroxyl coca*
14. The substance produced by a cell in viral infection that can protect other cells from further infection is:
- a. serotonin
 - b. colostrum
 - c. interferon
 - d. histamine
15. Transplantation of tissues/organs to save certain patients often fails due to rejection of such tissues/organs by the patient. Which type of immune response is responsible for such rejections?
- a. auto-immune response
 - b. humoral immune response
 - c. physiological immune response
 - d. cell-mediated immune response
16. Antibodies present in colostrum which protect the new born from certain diseases is of
- a. Ig G type
 - b. Ig A type
 - c. Ig D type
 - d. Ig E type

17. Tobacco consumption is known to stimulate secretion of adrenaline and nor-adrenaline. The component causing this could be:
- Nicotine
 - Tannic acid
 - Curaimin
 - Catechin
18. Anti venom against snake poison contains:
- Antigens
 - Antigen-antibody complexes
 - Antibodies
 - Enzymes
19. Which of the following is not a lymphoid tissue?
- Spleen
 - Tonsils
 - Appendix
 - Thymus
20. Which of the following glands is large sized at birth but reduces in size with aging?
- Pineal
 - Pituitary
 - Thymus
 - Thyroid
21. Haemozoin is:
- a precursor of hemoglobin
 - a toxin from *Streptococcus*
 - a toxin from *Plasmodium* species
 - a toxin from *Haemophilus* species
22. One of the following is not the causal organism for ringworm
- Microsporum*
 - Trichophyton*
 - Epidermophyton*
 - Macrosporum*

23. A person with sickle cell anemia is
- more prone to malaria
 - more prone to typhoid
 - less prone to malaria
 - less prone to typhoid

VERY SHORT ANSWER TYPE QUESTIONS

- Certain pathogens are tissue/organ specific. Justify the statement with suitable examples.
- The immune system of a person is suppressed. In the ELISA test, he was found positive to a pathogen.
 - Name the disease the patient is suffering from.
 - What is the causative organism?
 - Which cells of body are affected by the pathogen?
- Where are B-cells and T-cells formed? How do they differ from each other?
- Given below are the pairs of pathogens and the diseases caused by them. Which out of these is not a matching pair and why?
 - Virus common cold
 - Salmonella* typhoid
 - Microsporum* filariasis
 - Plasmodium* malaria
- What would happen to immune system, if thymus gland is removed from the body of a person?
- Many microbial pathogens enter the gut of humans along with food. What are the preventive barriers to protect the body from such pathogens? What type of immunity do you observe in this case?
- Why is mother's milk considered the most appropriate food for a new born infant?
- What are interferons? How do interferons check infection of new cells?

9. In the figure, structure of an antibody molecule is shown. Name the parts A, B and C.

Show A, B and C in the diagram.

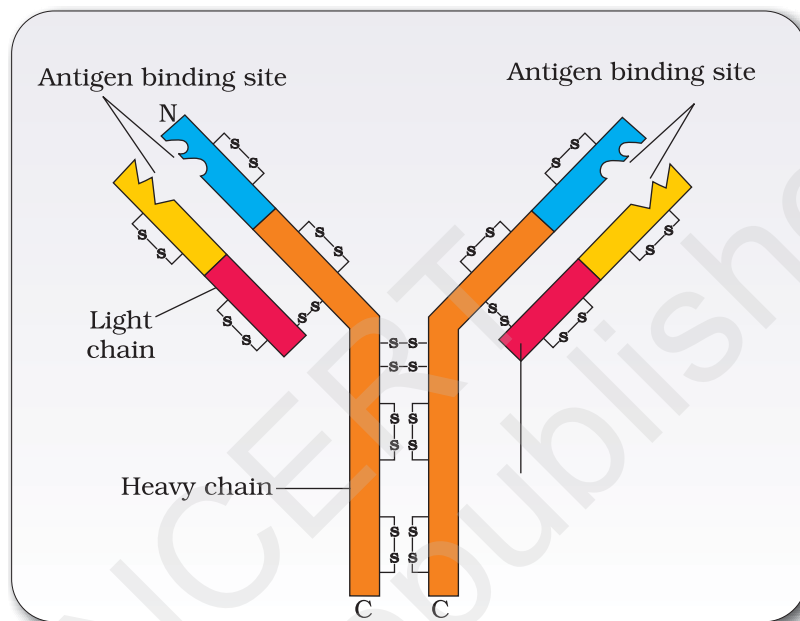

10. If a regular dose of drug or alcohol is not provided to an addicted person, he shows some withdrawal symptoms. List any four such withdrawal symptoms.
11. Why is it that during changing weather, one is advised to avoid closed, crowded and airconditioned places like cinema halls etc.?
12. The harmful allele of sickle cell anemia has not been eliminated from human population. Such afflicted people derive some other benefit. Discuss.
13. Lymph nodes are secondary lymphoid organs. Explain the role of lymph nodes in our immune response.
14. Why is an antibody molecule represented as H_2L_2 ?
15. What does the term 'memory' of the Immune system mean?
16. If a patient is advised Anti Retroviral Therapy, which infection is he suffering from? Name the causative organism.

SHORT ANSWER TYPE QUESTIONS

1. Differentiate between active immunity and passive immunity.
2. Differentiate between benign tumor and malignant tumor.
3. Do you consider passive smoking is more dangerous than active smoking? Why?
4. "Prevention is better than cure". Comment.
5. Explain any three preventive measures to control microbial infections.
6. In the given flow diagram, the replication of retrovirus in a host is shown. Observe and answer the following questions.
 - a. Fill in (1) and (2)
 - b. Why is the virus called retrovirus?
 - c. Can the infected cell survive while viruses are being replicated and released?

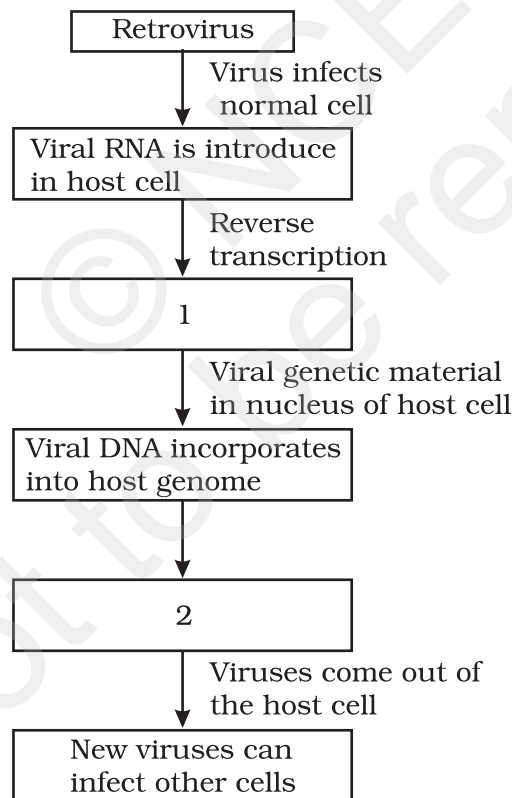

7. "Maintenance of personal and public hygiene is necessary for prevention and control of many infectious diseases". Justify the statement giving suitable examples.
8. The following table shows certain diseases, their causative organisms and symptoms. Fill the gaps.

	Name of the Disease	Causative organism	Symptoms
(i)	Ascariasis	<i>Ascaris</i>	_____
(ii)	_____	<i>Trichophyton</i>	Appearance of dry, scaly lesions on various parts of the body
(iii)	Typhoid	_____	High fever, weakness, headache, stomach pain, constipation.
(iv)	Pneumonia	<i>Streptococcus pneumoniae</i>	_____
(v)	_____	<i>Rhino viruses</i>	Nasal congestion and discharge, sorethroat, cough, headache
(vi)	Filariasis	_____	Inflammation in lower limbs

9. The outline structure of a drug is given below.
- Which group of drugs does this represent?
 - What are the modes of consumption of these drugs?
 - Name the organ of the body which is affected by consumption of these drugs.

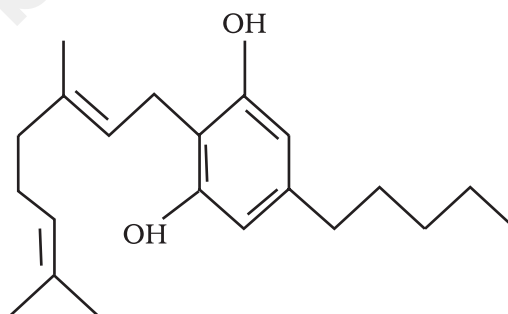

10. Give the full form of CT and MRI. How are they different from each other? Where are they used?
11. Many secondary metabolites of plants have medicinal properties. It is their misuse that creates problems. Justify the statement with an example.

12. Why cannabinoids are banned in sports and games?
13. What is secondary metabolism?
14. Drugs and alcohol give short-term 'high' and long-term 'damages', Discuss.
15. Diseases like dysentery, cholera, typhoid etc., are more common in over crowded human settlements. Why?
16. From which plant cannabinoids are obtained? Name any two cannabinoids. Which part of the body is effected by consuming these substances?
17. In the metropolitan cities of India, many children are suffering from allergy/asthma. What are the main causes of this problem. Give some symptoms of allergic reactions.
18. What is the basic principle of vaccination? How do vaccines prevent microbial infections? Name the organism from which hepatitis B Vaccine is produced.
19. What is cancer? How is a cancer cell different from the normal cell? How do normal cells attain cancerous nature?
20. A person shows strong unusual hypersensitive reactions when exposed to certain substances present in the air. Identify the condition. Name the cells responsible for such reactions. What precaution should be taken to avoid such reactions.
21. For an organ transplant, it is an advantage to have an identical twin. Why?
22. What are lifestyle diseases? How are they caused? Name any two such diseases.
23. If there are two pathogenic viruses, one with DNA and other with RNA, which would mutate faster? And Why?

LONG ANSWER TYPE QUESTIONS

1. Represent schematically the life cycle of a malarial parasite.
2. Compare the life style of people living in the urban areas with those of rural areas and briefly describe how the life style affects their health.
3. Why do some adolescents start taking drugs. How can this be avoided?
4. In your locality, if a person is addicted to alcohol, what kind of behavioural changes do you observe in that person? Suggest measures to over come the problem.

5. What are the methods of cancer detection? Describe the common approaches for treatment of cancer.
6. Drugs like LSD, barbiturates, amphetamines, etc., are used as medicines to help patients with mental illness. However, excessive doses and abusive usage are harmful. Enumerate the major adverse effects of such drugs in humans.
7. What is Pulse Polio Programme of Government of India? What is OPV? Why is it that India is yet to eradicate Polio?
8. What are recombinant DNA vaccines? Give two examples of such vaccines. Discuss their advantages.

© NCERT
not to be republished

CHAPTER 9

STRATEGIES FOR ENHANCEMENT IN FOOD PRODUCTION

MULTIPLE - CHOICE QUESTIONS

1. The chances of contacting bird flu from a properly cooked (above 100°C) chicken and egg are:
 - a. very high
 - b. high
 - c. moderate
 - d. none
2. A group of animals which are related by descent and share many similarities are referred to as:
 - a. breed
 - b. race
 - c. variety
 - d. species
3. Inbreeding is carried out in animal husbandry because it:
 - a. increases vigour
 - b. improves the breed
 - c. increases heterozygosity
 - d. increases homozygosity
4. Sonalika and Kalyan Sona are varieties of:
 - a. wheat
 - b. rice
 - c. millet
 - d. tobacco

5. Which one of the following is not a fungal disease?
 - a. Rust of wheat
 - b. Smut of Bajra
 - c. Black rot of crucifers
 - d. Red rot of sugarcane

6. In virus-infected plants the meristematic tissues in both apical and axillary buds are free of virus because:
 - a. the dividing cells are virus resistant
 - b. meristems have anti viral compounds
 - c. the cell division of meristems are faster than the rate of viral multiplication
 - d. Viruses cannot multiply within meristem cell (s).

7. Several South Indian states raise 2-3 crops of rice annually. The agronomic feature that makes this possible is because of
 - a. shorter rice plant
 - b. better irrigation facilities
 - c. early yielding rice variety
 - d. disease resistant rice variety.

8. Which one of the following combination would a sugarcane farmer look for in the sugarcane crop?
 - a. Thick stem, long internodes, high sugar content and disease resistant
 - b. Thick stem, high sugar content and profuse flowering
 - c. Thick stem, short internodes, high sugar content, disease resistant
 - d. Thick stem, low sugar, content, disease resistant

9. Fungicides and antibiotics are chemicals that:
 - a. enhance yield and disease resistance
 - b. kill pathogenic fungi and bacteria, respectively
 - c. kill all pathogenic microbes
 - d. kill pathogenic bacteria and fungi respectively.

10. Use of certain chemicals and radiation to change the base sequences of genes of crop plants is termed:
 - a. recombinant DNA technology
 - b. transgenic mechanism
 - c. mutation breeding
 - d. gene therapy.

11. The scientific process by which crop plants are enriched with certain desirable nutrients is called:
- crop protection
 - breeding
 - bio-fortification
 - bio-remediation.
12. The term 'totipotency' refers to the capacity of a:
- cell to generate whole plant
 - bud to generate whole plant
 - seed to germinate
 - cell to enlarge in size.
13. Given below are a few statements regarding somatic hybridization. Choose the correct statements.
- protoplasts of different cells of the same plant are fused
 - protoplasts from cells of different species can be fused
 - treatment of cells with cellulase and pectinase is mandatory
 - the hybrid protoplast contains characters of only one parental protoplast.
- a. (ii) and (iii) b. (i) and (ii) c. (iii) and (ii) d. (ii) and (iii)
14. An explant is:
- dead plant
 - part of the plant
 - part of the plant used in tissue culture
 - part of the plant that expresses a specific gene.
15. The biggest constraint of plant breeding is:
- availability of desirable gene in the crop and its wild relatives
 - infrastructure
 - trained manpower
 - transfer of genes from unrelated sources.
16. Lysine and tryptophan are:
- proteins
 - non-essential amino acids
 - essential amino acids
 - aromatic and no acids.
17. Micro-propagation is:
- propagation of microbes *in vitro*
 - propagation of plants *in vitro*

- c. propagation of cells *in vitro*
 - d. growing plants on smaller scale.
18. Protoplast is:
- a. another name for protoplasm
 - b. an animal cell
 - c. a plant cell without a cell wall
 - d. a plant cell.
19. To isolate protoplast, one needs:
- a. pectinase
 - b. cellulase
 - c. both pectinase and cellulase
 - d. chitinase.
20. Which one of the following is a marine fish:
- a. Rohu
 - b. Hilsa
 - c. Catla
 - d. Common Carp.
21. Which one of the following products of apiculture is used in cosmetics and polishes:
- a. honey
 - b. oil
 - c. wax
 - d. Royal jelly
22. More than 70 per cent of livestock population is in:
- a. Denmark
 - b. India
 - c. China
 - d. India and China.
23. The agriculture sector of India employs:
- a. 60 per cent of the population
 - b. 70 per cent of the population
 - c. 30 per cent of the population
 - d. 62 per cent of the population.
24. 33 percent of India's (Gross Domestic Product) comes from
- a. Industry
 - b. Agriculture

- c. Export
 - d. Small-scale cottage industries.
25. A collection of all the alleles of all the genes of a crop plant is called:
- a. germplasm collection
 - b. protoplasm collection
 - c. herbarium
 - d. somaclonal collection

VERY SHORT ANSWER TYPE QUESTIONS

1. Millions of chicken were killed in West Bengal, Assam, Orissa and Maharashtra recently. What was the reason?
2. Can gamma rays used for crop improvement programmes prove to be harmful for health? Discuss.
3. In animal husbandry, if two closely related animals are mated for a few generations, it results in loss of fertility and vigour. Why is this so?
4. In the area of plant breeding, it is important not only to preserve the seeds of the variety being cultivated, but also to preserve all its wild relatives. Explain with a suitable example.
5. Name a man-made cereal? Trace how it was developed and where is it used?
6. Fill in the blanks

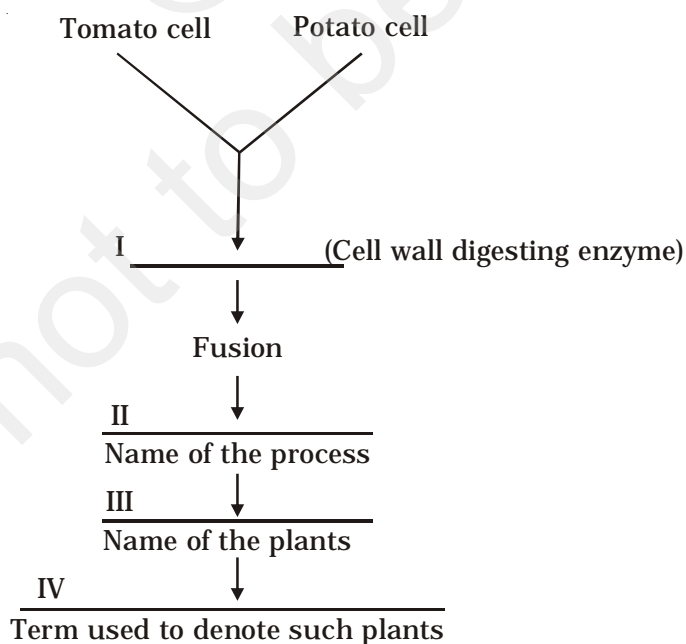

7. A few statements are given below followed by a set of terms in a box. Pick the correct term and write it against the appropriate statement
- Mating of closely related individuals within the same breed
 - Mating of animals of same breed but having no common ancestors on either side for 4-6 generations
 - Mating of animals of two different species
 - Breeding of animals belonging to different breeds
-
- (i) Cross breeding, (ii) Inter-specific hybridization,
(iii) Out breeding, (iv) Out crossing, (v) Inbreeding
-
8. What is meant by 'hidden hunger'?
9. Why are plants obtained by protoplast culture called somatic hybrids?
10. What is protoplast fusion?
11. Why is it easier to culture meristems compared to permanent tissues?
12. Why are proteins synthesised from *Spirulina* called single cell proteins?
13. A person who is allergic to pulses was advised to take a capsule of *Spirulina* daily. Give the reasons for the advise.
14. What is aquaculture? Give example of an animal that can be multiplied by aquaculture.
15. What are the duties of a veterinary doctor in management of a poultry farm?
16. Would it be wrong to call plants obtained through micro-propagation as 'clones'? Comment.
17. How is a somatic hybrid different from a hybrid?
18. What is emasculation? Why and when is it done?
19. Discuss the two main limitations of plant hybridization programme.
20. Interspecific crosses are rare in nature and intergeneric crosses almost unknown. Why?
21. Differentiate between pisciculture and aquaculture.
22. Give two important contributions of Dr. M. S. Swaminathan.
23. The term 'desirable trait' can mean different things for different plants. Justify the statement with suitable examples.

SHORT ANSWER TYPE QUESTIONS

1. You are planning to set up a Dairy Farm. Describe the various aspects you would consider before you start the venture.
2. It is said, that diseases are spreading faster due to globalisation and increased movement of people. Justify the statement taking the example of H5N1 virus.
3. Explain the concept of the Blue Revolution.
4. A farmer was facing the problem of low yield from his farm. He was advised to keep a beehive in the vicinity. Why? How would the beehive help in enhancing yield?
5. Life style diseases are increasing alarmingly in India. We are also dealing with large scale malnutrition in the population. Is there any method by which we can address both of these problems together?
6. How can we improve the success rate of fertilisation during artificial insemination in animal husbandry programmes?
7. What is meant by germplasm collection? What are its benefits?
8. Name the improved characteristics of wheat that helped India to achieve green revolution.
9. Suggest some of the features of plants that will prevent insect and pest infestation
10. It is easier to culture plant cells *in vitro* as compared to animal cells. Why?
11. The culture medium (nutrient medium) can be referred to as a 'highly enriched laboratory soil. Justify the statement.
12. Is there any relationship between dedifferentiation and the higher degree of success achieved in plant tissue culture experiments?
13. "Give me a living cell of any plant and I will give you a thousand plants of the same type" Is this only a slogan or is it scientifically possible? Write your comments and justify them.
14. What is the difference between a breed and a species? Give an example for each category.
15. Plants raised through tissue cultures are clones of the 'parent' plant. Discuss the utility of these plants.
16. Discuss the importance of testing of new plant varieties in a geographically vast country like India.

17. Define the term 'stress' for plants. Discuss briefly the two types of stress encountered by plants.
18. Discuss natural selection and artificial selection. What are the implications of the latter on the process of evolution?
19. Discuss briefly how pure lines are created in animal husbandry.
20. What are the physical barriers of a cell in the protoplast fusion experiment? How are the barriers overcome?
21. Give few examples of biofortified crops. What benefits do they offer to the society?

LONG ANSWER QUESTIONS

1. You are a Botanist working in the area of plant breeding. Describe the various steps that you will undertake to release a new variety.
2. (a) The shift from grain to meat diets creates more demands for cereals. Why?
(b) A 250 kg cow produces 200 g of protein per day but 250 g of *Methylophilus methylotrophus* can produce 25 tonnes of protein. Name this emerging area of research. Explain its benefits.
3. What are the advantages of tissue culture methods over conventional method of plant breeding in crop improvement programmes?
4. 'Modern methods of breeding animals and plants can alleviate the global food shortage'. Comment on the statement and give suitable examples.
5. Does apiculture offer multiple advantages to farmers? List its advantages if it is located near a place of commercial flower cultivation.
6. (a) Mutations are beneficial for plant breeding. Taking an example, justify the statement.
(b) Discuss briefly the technology that made us self-sufficient in food production.
7. Discuss how the property of plant cell totipotency has been utilised for plant propagation and improvement
8. What are three options to increase food production? Discuss each giving the salient features, merits and demerits.

CHAPTER 10

MICROBES IN HUMAN WELFARE

MULTIPLE-CHOICE QUESTIONS

- The vitamin whose content increases following the conversion of milk into curd by lactic acid bacteria is:
 - vitamin C
 - vitamin D
 - vitamin B₁₂
 - vitamin E.
- Wastewater treatment generates a large quantity of sludge, which can be treated by:
 - digesters
 - activated sludge
 - chemicals
 - oxidation pond.
- Methanogenic bacteria are not found in:
 - rumen of cattle
 - gobar gas plant
 - bottom of water-logged paddy fields
 - activated sludge.
- Match the following list of bacteria and their commercially important products:

Bacterium	Product
(i) <i>Aspergillus niger</i>	(a) Lactic acid
(ii) <i>Acetobacter aceti</i>	(b) Butyric acid
(iii) <i>Clostridium butylicum</i>	(c) Acetic acid
(iv) <i>Lactobacillus</i>	(d) Citric acid

Choose the correct match:

 - i b, ii c, iii d, iv a
 - i b, ii d, iii c, iv a

- c. i d, ii c, iii b, iv a
- d. i d, ii a, iii c, iv b

5. Match the following list of bioactive substances and their roles:

Bioactive Substance	Role
(i) Statin	(a) Removal of oil stains
(ii) Cyclosporin A	(b) Removal of clots from blood vessels
(iii) Streptokinase	(c) Lowering of blood cholesterol
(iv) Lipase	(d) Immuno-suppressive agent

Choose the correct match:

- a. i b, ii c, iii a, iv d
 - b. i d, ii b, iii a, iv c
 - c. i d, ii a, iii d, iv c
 - d. i c, ii d, iii b, iv a
6. The primary treatment of waste water involves the removal of:
- a. dissolved impurities
 - b. stable particles
 - c. toxic substances
 - d. harmful bacteria.
7. BOD of waste water is estimated by measuring the amount of:
- a. total organic matter
 - b. biodegradable organic matter
 - c. oxygen evolution
 - d. oxygen consumption.
8. Which one of the following alcoholic drinks is produced without distillation?
- a. Wine
 - b. Whisky
 - c. Rum
 - d. Brandy
9. The technology of biogas production from cow dung was developed in India largely due to the efforts of:
- a. Gas Authority of India
 - b. Oil and Natural Gas Commission
 - c. Indian Agricultural Research Institute and Khadi & Village Industries Commission
 - d. Indian Oil Corporation.

10. The free-living fungus *Trichoderma* can be used for:
 - a. killing insects
 - b. biological control of plant diseases
 - c. controlling butterfly caterpillars
 - d. producing antibiotics
11. What would happen if oxygen availability to activated sludge flocs is reduced?
 - a. It will slow down the rate of degradation of organic matter
 - b. The center of flocs will become anoxic, which would cause death of bacteria and eventually breakage of flocs.
 - c. Flocs would increase in size as anaerobic bacteria would grow around flocs.
 - d. Protozoa would grow in large numbers.
12. Mycorrhiza does not help the host plant in:
 - a. Enhancing its phosphorus uptake capacity
 - b. Increasing its tolerance to drought
 - c. Enhancing its resistance to root pathogens
 - d. Increasing its resistance to insects.
13. Which one of the following is not a nitrogen-fixing organism?
 - a. *Anabaena*
 - b. *Nostoc*
 - c. *Azotobacter*
 - d. *Pseudomonas*
14. Big holes in Swiss cheese are made by a:
 - a. a machine
 - b. a bacterium that produces methane gas
 - c. a bacterium producing a large amount of carbon dioxide
 - d. a fungus that releases a lot of gases during its metabolic activities.
15. The residue left after methane production from cattle dung is:
 - a. burnt
 - b. buried in landfills
 - c. used as manure
 - d. used in civil construction.
16. Methanogens do not produce:
 - a. oxygen
 - b. methane

- c. hydrogen sulfide
d. carbon dioxide.
17. Activated sludge should have the ability to settle quickly so that it can:
- be rapidly pumped back from sedimentation tank to aeration tank
 - absorb pathogenic bacteria present in waste water while sinking to the bottom of the settling tank
 - be discarded and anaerobically digested
 - absorb colloidal organic matter.
18. Match the items in Column 'A' and Column 'B' and choose correct answer.
- | Column A | Column B |
|--------------------------|------------------------|
| (i) Lady bird | (a) Methano bacterium |
| (ii) Mycorrhiza | (b) <i>Trichoderma</i> |
| (iii) Biological control | (c) Aphids |
| (iv) Biogas | (d) <i>Glomus</i> |
- The correct answer is:
- i b, ii d, iii c, iv a
 - i c, ii d, iii b, iv a
 - i d, ii a, iii b, iv c
 - i c, ii b, iii a, iv d
19. Which one is the most important role of micro organism for the well-being of humans?
- sewage treatment
 - production of methane
 - biological control of plant disease
 - conversion of milk to curd.

VERY SHORT ANSWER TYPE QUESTIONS

- Why does 'Swiss cheese' have big holes?
- What are fermentors?
- Name a microbe used for statin production. How do statins lower blood cholesterol level?
- Why do we prefer to call secondary waste water treatment as biological treatment?
- What for Nucleopolyhydro viruses are being used now a days?

6. How has the discovery of antibiotics helped mankind in the field of medicine?
7. Why is distillation required for producing certain alcoholic drinks?
8. Write the most important characteristic that *Aspergillus niger*, *Clostridium butylicum*, and *Lactobacillus* share.
9. What would happen if our intestine harbours microbial flora exactly similar to that found in the rumen of cattle?
10. Give any two microbes that are useful in biotechnology.
11. What is the source organism for ECORI, restriction endonuclease?
12. Name any genetically modified crop.
13. Why are blue green algae not popular as biofertilisers?
14. Which species of *Penicillium* produces Roquefort cheese?
15. Name the states involved in Ganga action plan.
16. Name any two industrially important enzymes.
17. Name an immune immunosuppressive agent?
18. Give an example of a rod shaped virus.
19. What is the group of bacteria found in both the rumen of cattle and shidge of sewage treatment?
20. Name a microbe used for the production of Swiss cheese.

SHORT ANSWER TYPE QUESTIONS

1. Why are flocs important in biological treatment of waste water?
2. How has the bacterium *Bacillus thuringiensis* helped us in controlling caterpillars of insect pests?
3. How do mycorrhizal fungi help the plants harbouring them?
4. Why are cyanobacteria considered useful in paddy fields?
5. How was penicillin discovered?
6. Name the scientists who were credited for showing the role of Penicillin as an antibiotic?
7. How do bioactive molecules of fungal origin help in restoring good health of humans?

8. What roles do enzymes play in detergents that we use for washing clothes? Are these enzymes produced from some unique microorganisms?
9. What is the chemical nature of biogas. Name an organism which is involved in biogas production?
10. How do microbes reduce the environmental degradation caused by chemicals?
11. What is a broad spectrum antibiotic? Name one such antibiotic.
12. What are viruses parasitising bacteria called? Draw a well labelled diagram of the same.
13. Which bacterium has been used as a clot buster? What is its mode of action.
14. What are biofertilisers? Give two examples.

LONG ANSWER QUESTIONS

1. Why is aerobic degradation more important than anaerobic degradation for the treatment of large volumes of waste waters rich in organic matter. Discuss.
2. (a) Discuss about the major programs that the Ministry of Environment and Forests, Government of India, has initiated for saving major Indian rivers from pollution.
(b) Ganga has recently been declared the national river. Discuss the implication with respect to pollution of this river.
3. Draw a diagrammatic sketch of biogas plant, and label its various components given below: Gas Holder, Sludge Chamber, Digester, Dung+water chamber.
4. Describe the main ideas behind the biological control of pests and diseases.
5. (a) What would happen if a large volume of untreated sewage is discharged into a river?
(b) In what way anaerobic sludge diagection is important in sewage treatments?
6. Which type of food would have lactic acid bacteria. Discuss their useful application.

CHAPTER 11

BIOTECHNOLOGY: PRINCIPLES AND PROCESSES

MULTIPLE-CHOICE QUESTIONS

1. Rising of dough is due to:
 - a. Multiplication of yeast
 - b. Production of CO₂
 - c. Emulsification
 - d. Hydrolysis of wheat flour starch into sugars.
2. An enzyme catalysing the removal of nucleotides from the ends of DNA is:
 - a. endonuclease
 - b. exonuclease
 - c. DNA ligase
 - d. Hind - II
3. The transfer of genetic material from one bacterium to another through the mediation of a vector like virus is termed as:
 - a. Transduction
 - b. Conjugation
 - c. Transformation
 - d. Translation
4. Which of the given statement is correct in the context of observing DNA separated by agarose gel electrophoresis?
 - a. DNA can be seen in visible light
 - b. DNA can be seen without staining in visible light
 - c. Ethidium bromide stained DNA can be seen in visible light
 - d. Ethidium bromide stained DNA can be seen under exposure to UV light

5. 'Restriction' in Restriction enzyme refers to:
 - a. Cleaving of phosphodiester bond in DNA by the enzyme
 - b. Cutting of DNA at specific position only
 - c. Prevention of the multiplication of bacteriophage in bacteria
 - d. All of the above

6. A recombinant DNA molecule can be produced in the absence of the following:
 - a. Restriction endonuclease
 - b. DNA ligase
 - c. DNA fragments
 - d. *E.coli*

7. In agarose gel electrophoresis, DNA molecules are separated on the basis of their:
 - a. Charge only
 - b. Size only
 - c. Charge to size ratio
 - d. All of the above

8. The most important feature in a plasmid to be used as a vector is:
 - a. Origin of replication (ori)
 - b. Presence of a selectable marker
 - c. Presence of sites for restriction endonuclease
 - d. Its size

9. While isolating DNA from bacteria, which of the following enzymes is not used?
 - a. Lysozyme
 - b. Ribonuclease
 - c. Deoxyribonuclease
 - d. Protease

10. Which of the following has popularised the PCR (polymerase chain reactions)?
 - a. Easy availability of DNA template
 - b. Availability of synthetic primers
 - c. Availability of cheap deoxyribonucleotides
 - d. Availability of 'Thermostable' DNA polymerase

11. An antibiotic resistance gene in a vector usually helps in the selection of:
 - a. Competent cells
 - b. Transformed cells
 - c. Recombinant cells
 - d. None of the above

12. Significance of 'heat shock' method in bacterial transformation is to facilitate:
 - a. Binding of DNA to the cell wall
 - b. Uptake of DNA through membrane transport proteins
 - c. Uptake of DNA through transient pores in the bacterial cell wall
 - d. Expression of antibiotic resistance gene

13. The role of DNA ligase in the construction of a recombinant DNA molecule is:
 - a. Formation of phosphodiester bond between two DNA fragments
 - b. Formation of hydrogen bonds between sticky ends of DNA fragments
 - c. Ligation of all purime and pyrimidine bases
 - d. None of the above

14. Which of the following bacteria is not a source of restriction endonuclease?
 - a. *Haemophilus influenzae*
 - b. *Escherichia coli*
 - c. *Agrobacterium tumefaciens*
 - d. *Bacillus amyloli*

15. Which of the following steps are catalysed by Taq polymerase in a PCR reaction?
 - a. Denaturation of template DNA
 - b. Annealing of primers to template DNA
 - c. Extension of primer end on the template DNA
 - d. All of the above

16. A bacterial cell was transformed with a recombinant DNA that was generated using a human gene. However, the transformed cells did not produce the desired protein. Reasons could be:
 - a. Human gene may have intron which bacteria cannot process
 - b. Amino acid codons for humans and bacteria are different
 - c. Human protein is formed but degraded by bacteria
 - d. All of the above

17. Which of the following should be chosen for best yield if one were to produce a recombinant protein in large amounts?
 - a. Laboratory flask of largest capacity
 - b. A stirred-tank bioreactor without in-lets and out-lets
 - c. A continuous culture system
 - d. Any of the above
18. Who among the following was awarded the Nobel Prize for the development of PCR technique?
 - a. Herbert Boyer
 - b. Hargovind Khurana
 - c. Kary Mullis
 - d. Arthur Kornberg
19. Which of the following statements does not hold true for restriction enzyme?
 - a. It recognises a palindromic nucleotide sequence
 - b. It is an endonuclease
 - c. It is isolated from viruses
 - d. It produces the same kind of sticky ends in different DNA molecules

VERY SHORT ANSWER TYPE QUESTIONS

1. How is copy number of the plasmid vector related to yield of recombinant protein?
2. Would you choose an exonuclease while producing a recombinant DNA molecule?
3. What does H in 'd' and 'III' refer to in the enzyme *Hind* III?
4. Restriction enzymes should not have more than one site of action in the cloning site of a vector. Comment.
5. What does 'competent' refer to in competent cells used in transformation experiments?
6. What is the significance of adding proteases at the time of isolation of genetic material (DNA).
7. While doing a PCR, 'denaturation' step is missed. What will be its effect on the process?

8. Name a recombinant vaccine that is currently being used in vaccination program.
9. Do biomolecules (DNA, protein) exhibit biological activity in anhydrous conditions?
10. What modification is done on the Ti plasmid of *Agrobacterium tumefaciens* to convert it into a cloning vector?

SHORT ANSWER TYPE QUESTIONS

1. What is meant by gene cloning?
2. Both a wine maker and a molecular biologist who had developed a recombinant vaccine claim to be biotechnologists. Who in your opinion is correct?
3. A recombinant DNA molecule was created by ligating a gene to a plasmid vector. By mistake, an exonuclease was added to the tube containing the recombinant DNA. How does this affect the next step in the experiment i.e. bacterial transformation?
4. Restriction enzymes that are used in the construction of recombinant DNA are endonucleases which cut the DNA at 'specific-recognition sequence'. What would be the disadvantage if they do not cut the DNA at specific-recognition sequence?
5. A plasmid DNA and a linear DNA (both are of the same size) have one site for a restriction endonuclease. When cut and separated on agarose gel electrophoresis, plasmid shows one DNA band while linear DNA shows two fragments. Explain.
6. How does one visualise DNA on an agarose gel?
7. A plasmid without a selectable marker was chosen as vector for cloning a gene. How does this affect the experiment?
8. A mixture of fragmented DNA was electrophoresed in an agarose gel. After staining the gel with ethidium bromide, no DNA bands were observed. What could be the reason?
9. Describe the role of CaCl_2 in the preparation of competent cells?
10. What would happen when one grows a recombinant bacterium in a bioreactor but forget to add antibiotic to the medium in which the recombinant is growing?

11. Identify and explain steps 'A', 'B' and 'C' in the PCR diagram given below.

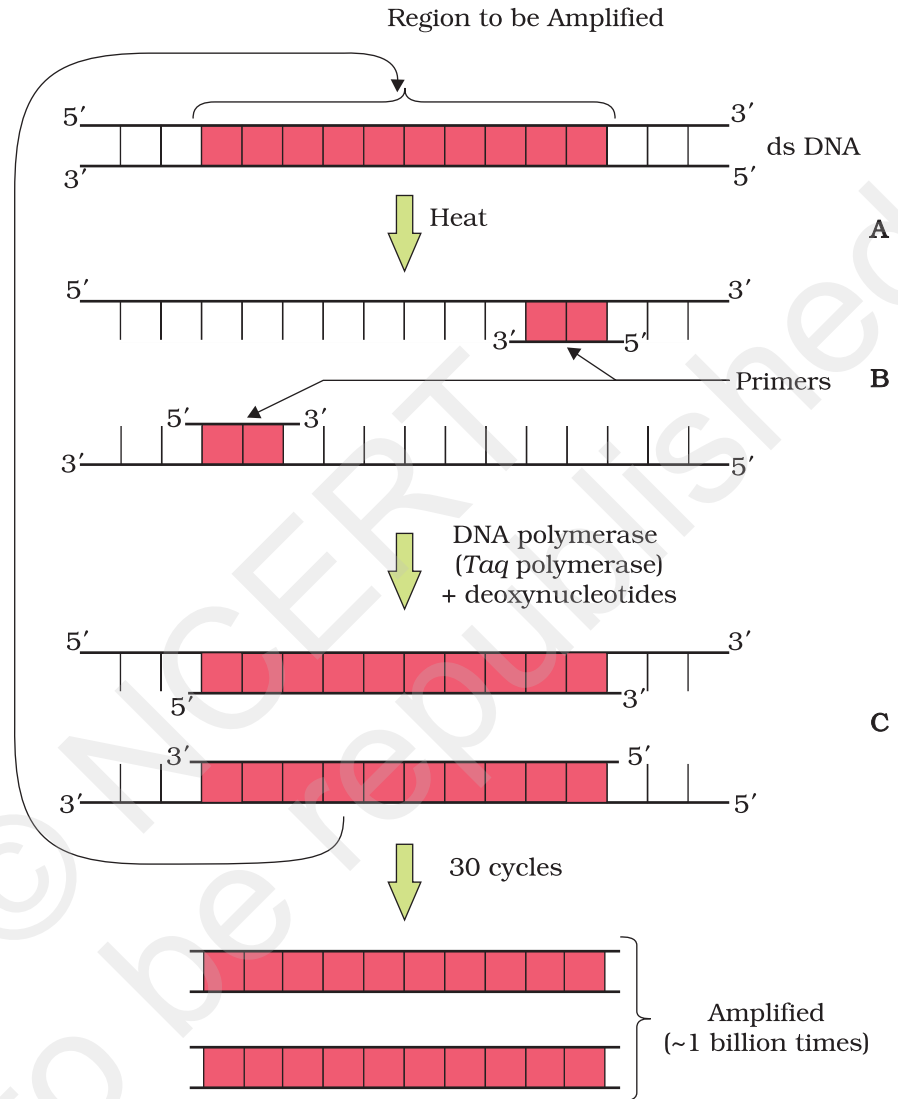

12. Name the regions marked A, B and C.

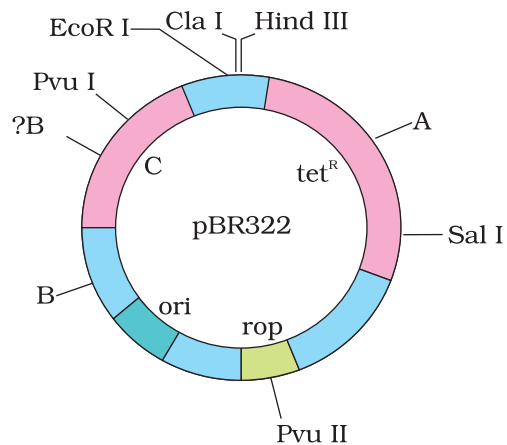

LONG ANSWER TYPE QUESTIONS

1. For selection of recombinants, insertional inactivation of antibiotic marker has been superceded by insertional inactivation of a marker gene coding for a chromogenic substrate. Give reasons.
2. Describe the role of *Agrobacterium tumefaciens* in transforming a plant cell.
3. Illustrate the design of a bioreactor. Highlight the difference between a flask in your laboratory and a bioreactor which allows cells to grow in a continuous culture system.

© NCERT
not to be republished

CHAPTER 12

BIOTECHNOLOGY AND ITS APPLICATIONS

MULTIPLE-CHOICE QUESTIONS

1. Bt cotton is not:
 - a. A GM plant
 - b. Insect resistant
 - c. A bacterial gene expressing system
 - d. Resistant to all pesticides
2. C-peptide of human insulin is:
 - a. A part of mature insulin molecule
 - b. Responsible for formation of disulphide bridges
 - c. Removed during maturation of pro-insulin to insulin
 - d. Responsible for its biological activity.
3. GEAC stands for:
 - a. Genome Engineering Action Committee
 - b. Ground Environment Action Committee
 - c. Genetic Engineering Approval Committee
 - d. Genetic and Environment Approval committee
4. α -1 antitrypsin is:
 - a. An antacid
 - b. An enzyme
 - c. Used to treat arthritis
 - d. Used to treat emphysema

5. A probe which is a molecule used to locate specific sequences in a mixture of DNA or RNA molecules could be:
 - a. A single stranded RNA
 - b. A single stranded DNA
 - c. Either RNA or DNA
 - d. Can be ss DNA but not ss RNA

6. Choose the correct option regarding Retrovirus:
 - a. An RNA virus that can synthesise DNA during infection
 - b. A DNA virus that can synthesise RNA during infection
 - c. A ssDNA virus
 - d. A dsRNA virus

7. The site of production of ADA in the body is:
 - a. Bone marrow
 - b. Lymphocytes
 - c. Blood plasma
 - d. Monocytes

8. A protoxin is:
 - a. A primitive toxin
 - b. A denatured toxin
 - c. Toxin produced by protozoa
 - d. Inactive toxin

9. Pathophysiology is the:
 - a. Study of physiology of pathogen
 - b. Study of normal physiology of host
 - c. Study of altered physiology of host
 - d. None of the above

10. The trigger for activation of toxin of *Bacillus thuringiensis* is:
 - a. Acidic pH of stomach
 - b. High temperature
 - c. Alkaline pH of gut
 - d. Mechanical action in the insect gut

11. Golden rice is:
 - a. A variety of rice grown along the yellow river in China
 - b. Long stored rice having yellow colour tint
 - c. A transgenic rice having gene for β -carotene
 - d. Wild variety of rice with yellow coloured grains

12. In RNAi, genes are silenced using:
 - a. ss DNA
 - b. ds DNA
 - c. ds RNA
 - d. ss RNA

13. The first clinical gene therapy was done for the treatment of:
 - a. AIDS
 - b. Cancer
 - c. Cystic fibrosis
 - d. SCID (Severe Combined Immuno Deficiency resulting from deficiency of ADA)

14. ADA is an enzyme which is deficient in a genetic disorder SCID. What is the full form of ADA?
 - a. Adenosine deoxy aminase
 - b. Adenosine deaminase
 - c. Aspartate deaminase
 - d. Arginine deaminase

15. Silencing of a gene could be achieved through the use of:
 - a. short interfering RNA (RNAi)
 - b. antisense RNA
 - c. by both
 - d. none of the above

VERY SHORT ANSWER TYPE QUESTIONS

1. In view of the current food crisis, it is said, that we need another green revolution. Highlight the major limitations of the earlier green revolution.
2. Expand GMO. How is it different from a hybrid?
3. Differentiate between diagnostics and therapeutics. Give one example and for each category.

4. Give the full form of ELISA. Which disease can be detected using it? Discuss the principle underlying the test.
5. Can a disease be detected before its symptoms appear? Explain the principle involved.
6. Write a short note on Biopiracy highlighting the exploitation of developing countries by the developed countries.
7. Many proteins are secreted in their inactive form. This is also true of many toxic proteins produced by micro organisms. Explain how the mechanism is useful for the organism producing the toxin?
8. While creating genetically modified organisms, genetic barriers are not respected. How can this be dangerous in the long run?
9. Why has the Indian Parliament cleared the second amendment of the country's patents bill?
10. Give any two reasons why the patent on *Basmati* should not have gone to an American Company.
11. How was Insulin obtained before the advent of rDNA technology? What were the problems encountered?
12. With respect to understanding diseases, discuss the importance of transgenic animal models.
13. Name the first transgenic cow. Which gene was introduced in this cow?
14. PCR is a useful tool for early diagnosis of an infectious disease. Elaborate.
15. What is GEAC and what are its objectives?
16. For which variety of Indian rice, the patent was filed by a USA Company?
17. Discuss the advantages of GMO.

SHORT ANSWER TYPE QUESTIONS

1. Gene expression can be controlled with the help of RNA. Explain the method with an example.
2. Ignoring our traditional knowledge can we prove costly in the area of biological patenting. Justify.
3. Highlight any four areas where genetic modification of plants has been useful.

4. What is a recombinant DNA vaccine? Give two examples.
5. Why is it that the line of treatment for a genetic disease is different from infectious diseases?
6. Discuss briefly how a probe is used in molecular diagnostics.
7. Who was the first patient who was given gene therapy? Why was the given treatment recurrent in nature?
8. Taking examples under each category, discuss upstream and downstream processing.
9. Define Antigen and Antibody. Name any two diagnostic kits based upon them.
10. ELISA technique is based on the principles of antigen-antibody interaction. Can this technique be used in the molecular diagnosis of a genetic disorder, such as phenylketonuria?
11. How is a mature, functional insulin hormone different from its prohormone form?
12. Gene therapy is an attempt to correct a genetic defect by providing a normal gene into the individual. By this the normal function can be restored. An alternate method would be to provide the gene product (protein/enzyme) known as enzyme replacement therapy, which would also restore the function. Which in your opinion is a better option? Give reason for your answer.
13. Transgenic animals are the animals in which a foreign gene is expressed. Such animals can be used to study the fundamental biological process, phenomenon as well as for producing products useful for mankind. Give one example for each type.
14. When a foreign DNA is introduced into an organism, how is it maintained in the host and how is it transferred to the progeny of the organism?
15. Bt cotton is resistant to pest, such as lepidopteron, dipterans and coleopterans. Is Bt cotton also resistant to other pests as well?

LONG ANSWER QUESTIONS

1. A patient is suffering from ADA deficiency. Can he be cured? How?
2. Define transgenic animals. Explain in detail any four areas where they can be utilised.

3. You have identified a useful gene in bacteria. Make a flow chart of the steps that you would follow to transfer this gene to a plant.
4. Highlight five areas where biotechnology has influenced our lives.
5. What are the various advantages of using genetically modified plants to increase the overall yield of the crop?
6. Explain with the help of one example how genetically modified plants can:
 - (a) Reduce usage of chemical pesticides
 - (b) Enhance nutritional value of food crops
7. List the disadvantages of insulin obtained from the pancreas of slaughtered cows and pigs:
8. List the advantages of recombinant insulin.
9. What is meant by the term bio-pesticide? Name and explain the mode of action of a popular bio-pesticide.
10. Name the five key tools for accomplishing the tasks of recombinant DNA technology. Also mention the functions of each tool.

CHAPTER 13

ORGANISMS AND POPULATIONS

MULTIPLE-CHOICE QUESTIONS

1. Autecology is the:
 - a. Relation of a population to its environment
 - b. Relation of an individual to its environment
 - c. Relation of a community to its environment
 - d. Relation of a biome to its environment

2. Ecotone is:
 - a. A polluted area
 - b. The bottom of a lake
 - c. A zone of transition between two communities
 - d. A zone of developing community

3. Biosphere is:
 - a. a component in the ecosystem
 - b. composed of the plants present in the soil
 - c. life in the outer space
 - d. composed of all living organisms present on earth which interact with the physical environment

4. Ecological niche is:
 - a. the surface area of the ocean
 - b. an ecologically adapted zone
 - c. the physical position and functional role of a species within the community
 - d. formed of all plants and animals living at the bottom of a lake

5. According to Allen's Rule, the mammals from colder climates have:
 - a. shorter ears and longer limbs
 - b. longer ears and shorter limbs
 - c. longer ears and longer limbs
 - d. shorter ears and shorter limbs

6. Salt concentration (Salinity) of the sea measured in parts per thousand is:
 - a. 10 - 15
 - b. 30 - 70
 - c. 0 - 5
 - d. 30 - 35

7. Formation of tropical forests needs mean annual temperature and mean annual precipitation as:
 - a. 18 - 25°C and 150 - 400 cm
 - b. 5 - 15°C and 50 - 100 cm
 - c. 30 - 50°C and 100 - 150 cm
 - d. 5 - 15°C and 100 - 200 cm

8. Which of the following forest plants controls the light conditions at the ground?
 - a. Lianas and climbers
 - b. Shrubs
 - c. Tall trees
 - d. Herbs

9. What will happen to a well growing herbaceous plant in the forest if it is transplanted outside the forest in a park?
 - a. It will grow normally
 - b. It will grow well because it is planted in the same locality
 - c. It may not survive because of change in its micro climate
 - d. It grows very well because the plant gets more sunlight

10. If a population of 50 *Paramecium* present in a pool increases to 150 after an hour, what would be the growth rate of population?
 - a. 50 per hour
 - b. 200 per hour
 - c. 5 per hour
 - d. 100 per hour

11. What would be the per cent growth or birth rate per individual per hour for the same population mentioned in the previous question (Question 10)?
- 100
 - 200
 - 50
 - 150
12. A population has more young individuals compared to the older individuals. What would be the status of the population after some years?
- It will decline
 - It will stabilise
 - It will increase
 - It will first decline and then stabilise
13. What parameters are used for tiger census in our country's national parks and sanctuaries?
- Pug marks only
 - Pug marks and faecal pellets
 - Faecal pellets only
 - Actual head counts
14. Which of the following would necessarily decrease the density of a population in a given habitat?
- Natality > mortality
 - Immigration > emigration
 - Mortality and emigration
 - Natality and immigration
15. A protozoan reproduces by binary fission. What will be the number of protozoans in its population after six generations?
- 128
 - 24
 - 64
 - 32
16. In 2005, for each of the 14 million people present in a country, 0.028 were born and 0.008 died during the year. Using exponential equation, the number of people present in 2015 is predicted as:
- 25 millions
 - 17 millions
 - 20 millions
 - 18 millions

17. Amensalism is an association between two species where:
 - a. one species is harmed and other is benefitted
 - b. one species is harmed and other is unaffected
 - c. one species is benefitted and other is unaffected
 - d. both the species are harmed.

18. Lichens are the associations of:
 - a. bacteria and fungus
 - b. algae and bacterium
 - c. fungus and algae
 - d. fungus and virus

19. Which of the following is a partial root parasite?
 - a. Sandal wood
 - b. Mistletoe
 - c. *Orobanche*
 - d. *Ganoderma*

20. Which one of the following organisms reproduces sexually only once in its life time?
 - a. Banana plant
 - b. Mango
 - c. Tomato
 - d. Eucalyptus

VERY SHORT ANSWER TYPE QUESTIONS

1. Species that can tolerate narrow range of temperature are called _____.
2. What are Eurythermic species?
3. Species that can tolerate wide range of salinity are called _____.
4. Define stenohaline species.
5. What is the interaction between two species called?
6. What is commensalism?
7. Name the association in which one species produces poisonous substance or a change in environmental conditions that is harmful to another species.
8. What is Mycorrhiza?

9. Emergent land plants that can tolerate the salinities of the sea are called.
10. Why do high altitude areas have brighter sunlight and lower temperatures as compared to the plains?
11. What is homeostasis?
12. Define aestivation.
13. What is diapause and its significance?
14. What would be the growth rate pattern, when the resources are unlimited?
15. What are the organisms that feed on plant sap and other plant parts called?
16. What is high altitude sickness? Write its symptoms.
17. Give a suitable example for commensalism.
18. Define ectoparasite and endoparasite and give suitable examples.
19. What is brood parasitism? Explain with the help of an example.

SHORT ANSWER TYPE QUESTIONS

1. Why are coral reefs not found in the regions from west Bengal to Andhra Pradesh but are found in Tamil Nadu and on the east coast of India?
2. If a fresh water fish is placed in an aquarium containing sea water, will the fish be able to survive? Explain giving reasons.
3. Why do all the fresh water organisms have contractile vacuoles whereas majority of marine organisms lack them?
4. Define heliophytes and sciophytes. Name a plant from your locality that is either heliophyte or sciophyte.
5. Why do submerged plants receive weaker illumination than exposed floating plants in a lake?
6. In a sea shore, the benthic animals live in sandy, muddy and rocky substrata and accordingly developed the following adaptations.
 - a. Burrowing
 - b. Building cubes
 - c. Holdfasts / peduncle

Find the suitable substratum against each adaptation.

7. Categorise the following plants into hydrophytes, halophytes, mesophytes and xerophytes. Give reasons for your answers.
- Salvinia*
 - Opuntia*
 - Rhizophora*
 - Mangifera*

8. In a pond, we see plants which are free-floating; rooted-submerged; rooted emergent; rooted with floating leaves. Write the type of plants against each of them.

Plant Name	Type
a. <i>Hydrilla</i>	_____
b. <i>Typha</i>	_____
c. <i>Nymphaea</i>	_____
d. <i>Lemna</i>	_____
e. <i>Vallisnaria</i>	_____

9. The density of a population in a habitat per unit area is measured in different units. Write the unit of measurement against the following:
- Bacteria _____
 - Banyan _____
 - Deer _____
 - Fish _____

10.

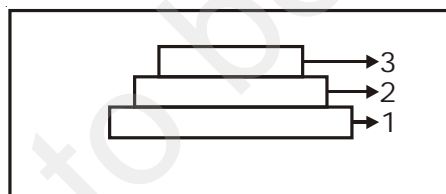

- Label the three tiers 1, 2, 3 given in the above age pyramid.
 - What type of population growth is represented by the above age pyramid?
11. In an association of two animal species, one is a termite which feeds on wood and the other is a protozoan *Trichonympha* present in the gut of the termite. What type of association they establish?
12. Lianas are vascular plants rooted in the ground and maintain erectness of their stem by making use of other trees for support. They do not maintain direct relation with those trees. Discuss the type of association the lianas have with the trees.

13. Give the scientific names of any two microorganisms inhabiting the human intestine.
14. What is a tree line?
15. Define 'zero population growth rate'. Draw a age pyramid for the same.
16. List any four characters that are employed in human population census.
17. Give one example for each of the following types.
 - a) Migratory animal
 - b) Camouflaged animal
 - c) Predator animal
 - d) Biological control agent
 - e) Phytophagous animal
 - f) Chemical defense agent

18. Fill in the blanks

Species A	Species B	Type of Interaction	Example
+	-	_____	_____
+	+	_____	_____
+	_____	Commensalism	_____

19. Observe the set of 4 figures A, B, C and D and, answer the following questions
- i. Which one of the figures shows mutualism?
 - ii. What kind of association is shown in D?
 - iii. Name the organisms and the association in C.
 - iv. What role is the insect performing in B?



Fig. (A)

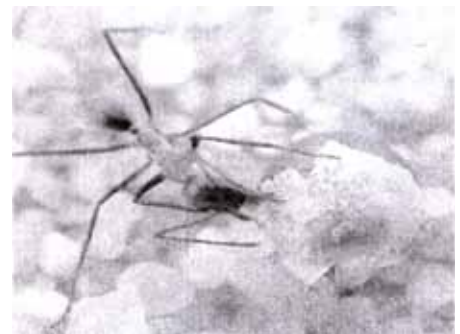

Fig. (B)



Fig. (C)



Fig. (D)

LONG ANSWER QUESTIONS

1. Comment on the following figures: 1, 2 and 3:
 A, B, C, D, G, P, Q, R, S are species

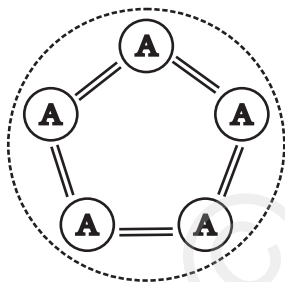

Fig. 1

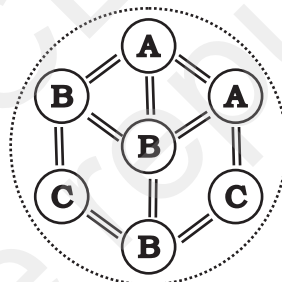

Fig. 2

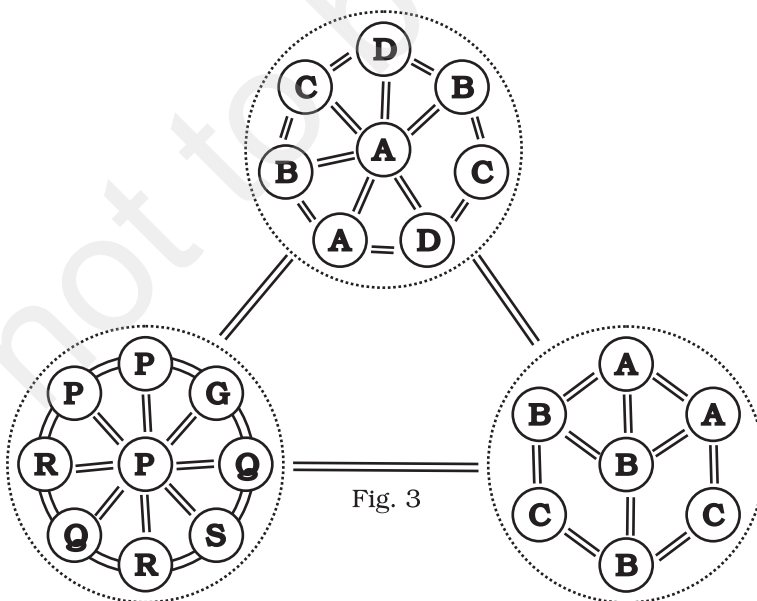
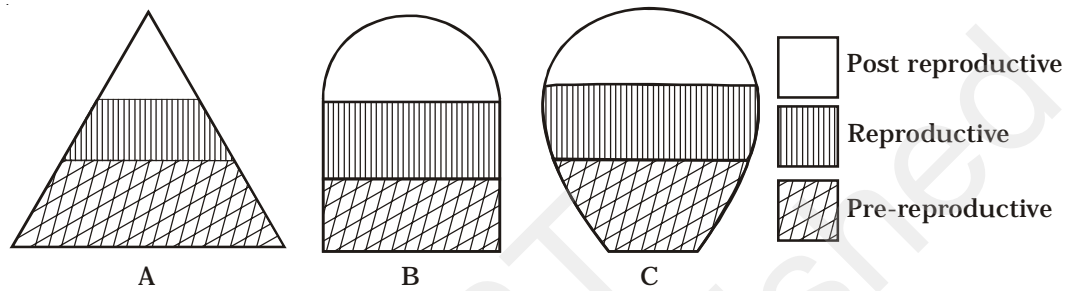
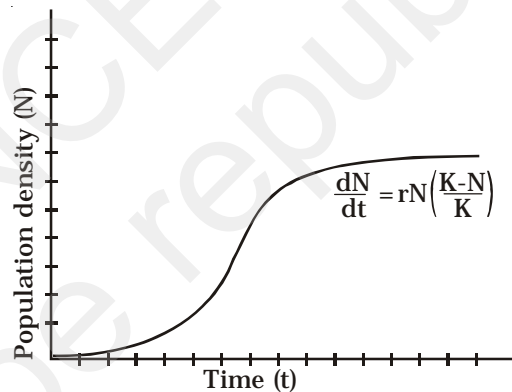

Fig. 3

- An individual and a population has certain characteristics. Name these attributes with definitions.
- The following diagrams are the age pyramids of different populations. Comment on the status of these populations.



- Comment on the growth curve given below.



- A population of *Paramecium caudatum* was grown in a culture medium. After 5 days the culture medium became overcrowded with *Paramecium* and had depleted nutrients. What will happen to the population and what type of growth curve will the population attain? Draw the growth curve.
- Discuss the various types of positive interactions between species.
- In an aquarium two herbivorous species of fish are living together and feeding on phytoplanktons. As per the Gause's Principle, one of the species is to be eliminated in due course of time, but both are surviving well in the aquarium. Give possible reasons.
- While living in and on the host species, the animal parasite has evolved certain adaptations. Describe these adaptations with examples.

9. Do you agree that regional and local variations exist within each biome? Substantiate your answer with suitable example.
10. Which element is responsible for causing soil salinity? At what concentration does the soil become saline?
11. Does light factor affect the distribution of organisms? Write a brief note giving suitable examples of either plants or animals.
12. Give one example for each of the following:
- | | |
|--|-------|
| i. Eurythermal plant species | _____ |
| ii. A hot water spring organism | _____ |
| iii. An organism seen in deep ocean trenches | _____ |
| iv. An organism seen in compost pit | _____ |
| v. A parasitic angiosperm | _____ |
| vi. A stenothermal plant species | _____ |
| vii. Soil organism | _____ |
| viii. A benthic animal | _____ |
| ix. Antifreeze compound seen in antarctic fish | _____ |
| x. An organism which can conform | _____ |

CHAPTER 14

ECOSYSTEM

MULTIPLE-CHOICE QUESTIONS

- Decomposers like fungi and bacteria are:
 - autotrophs
 - heterotrophs
 - saprotrophs
 - chemo-autotrophs.Choose the correct answer:
(a) i and iii, (b) i and iv (c) ii and iii, (d) i and ii
- The process of mineralisation by micro organisms helps in the release of:
 - inorganic nutrients from humus
 - both organic and inorganic nutrients from detritus
 - organic nutrients from humus
 - inorganic nutrients from detritus and formation of humus.
- Productivity is the rate of production of biomass expressed in terms of:
 - $(\text{kcal m}^{-3}) \text{ yr}^{-1}$
 - $\text{g}^{-2} \text{ yr}^{-1}$
 - $\text{g}^{-1} \text{ yr}^{-1}$
 - $(\text{kcal m}^{-2}) \text{ yr}^{-1}$(a) ii, (b) iii, (c) ii and iv, (d) i and iii
- An inverted pyramid of biomass can be found in which ecosystem?
 - Forest
 - Marine
 - Grass land
 - Tundra

5. Which of the following is not a producer?
 - a. *Spirogyra*
 - b. *Agaricus*
 - c. *Volvox*
 - d. *Nostoc*

6. Which of the following ecosystems is most productive in terms of net primary production?
 - a. Deserts
 - b. Tropical rain forests
 - c. Oceans
 - d. Estuaries

7. Pyramid of numbers is:
 - a. Always upright
 - b. Always inverted
 - c. Either upright or inverted
 - d. Neither upright nor inverted.

8. Approximately how much of the solar energy that falls on the leaves of a plant is converted to chemical energy by photosynthesis?
 - a. Less than 1%
 - b. 2-10%
 - c. 30%
 - d. 50%

9. Among the following, where do you think the process of decomposition would be the fastest?
 - a. Tropical rain forest
 - b. Antarctic
 - c. Dry arid region
 - d. Alpine region

10. How much of the net primary productivity of a terrestrial ecosystem is eaten and digested by herbivores?
 - a. 1%
 - b. 10%
 - c. 40%
 - d. 90%

11. During the process of ecological succession the changes that take place in communities are:
 - a. Orderly and sequential
 - b. Random
 - c. Very quick
 - d. Not influenced by the physical environment.

12. Climax community is in a state of:
 - a. non-equilibrium
 - b. equilibrium
 - c. disorder
 - d. constant change.

13. Among the following bio-geo-chemical cycles which one does not have losses due to respiration?
 - a. Phosphorus
 - b. Nitrogen
 - c. Sulphur
 - d. All of the above

14. The sequence of communities of primary succession in water is:
 - a. phytoplankton, sedges, free-floating hydrophytes, rooted hydrophytes, grasses and trees.
 - b. phytoplankton, free-floating hydrophytes, rooted hydrophytes, sedges, grasses and trees.
 - c. free-floating hydrophytes, sedges, phytoplankton, rooted hydrophytes, grasses and trees.
 - d. phytoplankton, rooted submerged hydrophytes, floating hydrophytes, reed swamp, sedges, meadow and trees.

15. The reservoir for the gaseous type of bio-geo chemical cycle exists in
 - a. stratosphere
 - b. atmosphere
 - c. ionosphere
 - d. lithosphere

16. If the carbon atoms fixed by producers already have passed through three species, the trophic level of the last species would be.
 - a. scavenger
 - b. tertiary producer
 - c. tertiary consumer
 - d. secondary consumer

17. Which of the following type of ecosystem is expected in an area where evaporation exceeds precipitation, and mean annual rainfall is below 100mm
- Grassland
 - Shrubby forest
 - Desert
 - Mangrove
18. The zone at the edge of a lake or ocean which is alternatively exposed to air and immersed in water is called:
- Pelagic zone
 - Benthic zone
 - Lentic one
 - Littoral zone
19. Edaphic factor refers to:
- Water
 - Soil
 - Relative humidity
 - Altitude
20. Which of the following is an ecosystem service provided by a natural ecosystem?
- Cycling of nutrients
 - Prevention of soil erosion
 - Pollutant absorption and reduction of the threat of global warming
 - All of the above

VERY SHORT ANSWER TYPE QUESTIONS

- Name an organism found as secondary carnivore in an aquatic ecosystem.
- What does the base tier of the ecological pyramid represent?
- Under what conditions would a particular stage in the process of succession revert back to an earlier stage?
- Arrange the following as observed in vertical stratification of a forest: Grass, Shrubby plants, Teak, Amaranths.
- Name an omnivore which occurs in both grazing food chain and the decomposer food chain.

6. Justify the pitcher plant as a producer.
7. Name any two organisms which can occupy more than one trophic level in an ecosystem.
8. In the North East region of India, during the process of *jhum* cultivation, forests are cleared by burning and left for regrowth after a year of cultivation. How would you explain the regrowth of forest in ecological term?
9. Climax stage is achieved quickly in secondary succession as compared to primary succession. Why?
10. Among bryophytes, lichens and fern which one is a pioneer species in a xeric succession?
11. What is the ultimate source of energy for the ecosystems?
12. Is the common edible mushroom an autotroph or a heterotroph?
13. Why are oceans least productive?
14. Why is the rate of assimilation of energy at the herbivore level called secondary productivity?
15. Why are nutrient cycles in nature called biogeochemical cycles?
16. Give any two examples of xerarch succession.
17. Define self sustainability.
18. Given below is a figure of an ecosystem. Answer the following questions.



- i. What type of ecosystem is shown in the figure.
 - ii. Name any plant that is characteristic of such ecosystem.
19. What is common to earthworm, mushroom, soil mites and dung beetle in an ecosystem.

SHORT ANSWER TYPE QUESTIONS

1. Organisms at a higher trophic level have less energy available. Comment.
2. The number of trophic levels in an ecosystem are limited. Comment.
3. Is an aquarium a complete ecosystem?
4. What could be the reason for the faster rate of decomposition in the tropics?
5. Human activities interfere with carbon cycle. List any two such activities.
6. Flow of energy through various trophic levels in an ecosystem is unidirectional and non-cyclic. Explain.
7. Apart from plants and animals, microbes form a permanent biotic component in an ecosystem. While plants have been referred to as autotrophs and animals as heterotrophs, what are microbes referred to as? How do the microbes fulfil their energy requirements?
8. Poaching of tiger is a burning issue in today's world. What implication would this activity have on the functioning of the ecosystem of which the tigers are an integral part?
9. In relation to energy transfer in ecosystem, explain the statement "10kg of deer's meat is equivalent to 1 kg of lion's flesh".
10. Primary productivity varies from ecosystem to ecosystem. Explain?
11. Sometimes due to biotic/abiotic factor the climax remain in a particular seral stage (pre climax) without reaching climax. Do you agree with this statement. If yes give a suitable example.
12. What is an incomplete ecosystem? Explain with the help of suitable example.
13. What are the shortcomings of ecological pyramids in the study of ecosystem?
14. How do you distinguish between humification and mineralisation?
15. Fill in the trophic levels (1, 2, 3 and 4) in the boxes provided in the figure.

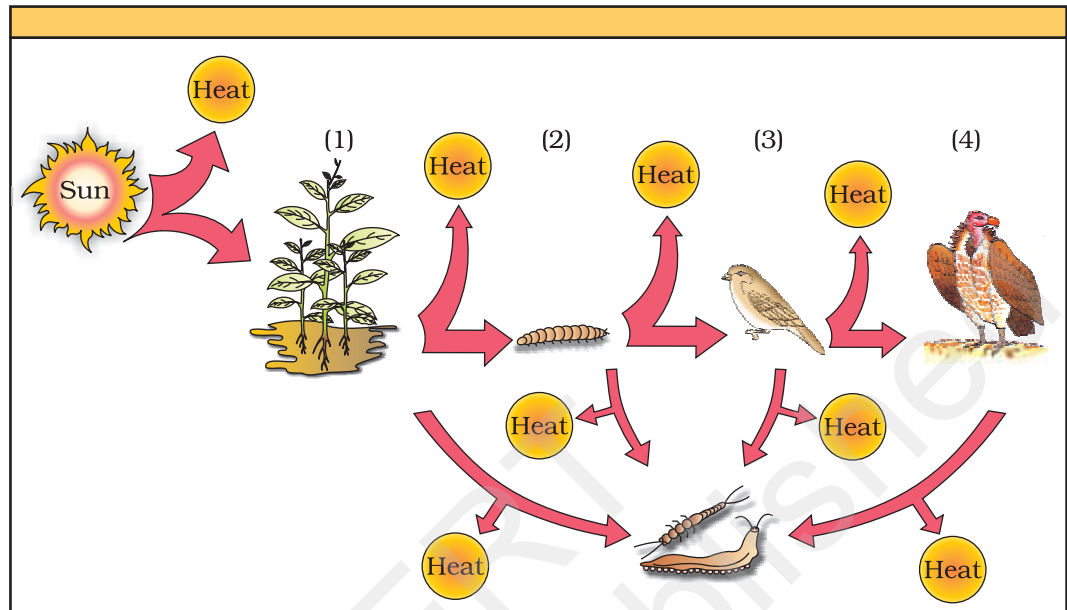

16. The rate of decomposition of detritus is affected by the abiotic factors like availability of oxygen, pH of the soil substratum, temperature etc. Discuss.

LONG ANSWER TYPE QUESTIONS

1. A farmer harvests his crop and expresses his harvest in three different ways.
 - a. I have harvested 10 quintals of wheat.
 - b. I have harvested 10 quintals of wheat today in one acre of land.
 - c. I have harvested 10 quintals of wheat in one acre of land, 6 months after sowing.

Do the above statements mean one and the same thing. If your answer is yes, give reasons. And if your answer is 'no' explain the meaning of each expression.

2. Justify the following statement in terms of ecosystem dynamics. "Nature tends to increase the gross primary productivity, while man tends to increase the net primary productivity".
3. Which of the following ecosystems will be more productive in terms of primary productivity? Justify your answer.

A young forest, a natural old forest, a shallow polluted lake, alpine meadow.

4. What are the three types of ecological pyramids. What information is conveyed by each pyramid with regard to structure, function and energy in the ecosystem.
5. Write a short note on pyramid of numbers and pyramid of biomass.
6. Given below is a list of autotrophs and heterotrophs. With your knowledge about food chain, establish various linkages between the organisms on the principle of 'eating and being eaten'. What is this inter-linkage established known as?

Algae, hydrilla, grasshopper, rat, squirrel, crow, maize plant, deer, rabbit, lizard, wolf, snake, peacock, phytoplankton, crustaceans, whale, tiger, lion, sparrow, duck, crane, cockroach, spider, toad, fish, leopard, elephant, goat, *Nymphaea*, *Spirogyra*.

7. "The energy flow in the ecosystem follows the second law of thermodynamics." Explain.
8. What will happen to an ecosystem if:
 - a. All producers are removed;
 - b. All organisms of herbivore level are eliminated; and
 - c. All top carnivore population is removed
9. Give two examples of artificial or man made ecosystems. List the salient features by which they differ from natural ecosystems.
10. The biodiversity increases when one moves from the pioneer to the climax stage. What could be the explanation?
11. What is a biogeochemical cycle. What is the role of the reservoir in a biogeochemical cycle. Give an example of a sedimentary cycle with reservoir located in earth's crust.
12. What will be the P/R ratio of a climax community and a pioneer community. What explanation could you offer for the changes seen in P/R ratio of a pioneer community and the climax community.

CHAPTER 15

BIODIVERSITY AND CONSERVATION

MULTIPLE-CHOICE QUESTIONS

1. Which of the following countries has the highest biodiversity?
 - a. Brazil
 - b. South Africa
 - c. Russia
 - d. India
2. Which of the following is not a cause for loss of biodiversity?
 - a. Destruction of habitat
 - b. Invasion by alien species
 - c. Keeping animals in zoological parks
 - d. Over-exploitation of natural resources
3. Which of the following is not an invasive alien species in the Indian context?
 - a. *Lantana*
 - b. *Cynodon*
 - c. *Parthenium*
 - d. *Eichhornia*
4. Where among the following will you find pitcher plant?
 - a. Rain forest of North-East India
 - b. Sunderbans
 - c. Thar Desert
 - d. Western Ghats
5. Which one of the following is not a major characteristic feature of biodiversity hot spots?
 - a. Large number of species
 - b. Abundance of endemic species
 - c. Large number of exotic species
 - d. Destruction of habitat

6. Match the animals given in column A with their location in column B:

Column A	Column B
(i) Dodo	(a) Africa
(ii) Quagga	(b) Russia
(iii) Thylacine	(c) Mauritius
(iv) Stellar's sea cow	(d) Australia

Choose the correct match from the following:

- (a) i-a, ii-c, iii-b, iv-d
 - (b) i-d, ii-c, iii-a, iv-b
 - (c) i-c, ii-a, iii-b, iv-d
 - (d) i-c, ii-a, iii-d, iv-b
7. What is common to the following plants: *Nepenthes*, *Psilotum*, *Rauwolfia* and *Aconitum*?
- a. All are ornamental plants
 - b. All are phylogenic link species
 - c. All are prone to over exploitation
 - d. All are exclusively present in the Eastern Himalayas.
8. The one-horned rhinoceros is specific to which of the following sanctuary
- a. Bhitara Kanika
 - b. Bandipur
 - c. Kaziranga
 - d. Corbett park
9. Amongst the animal groups given below, which one has the highest percentage of endangered species?
- a. Insects
 - b. Mammals
 - c. Amphibians
 - d. Reptiles
10. Which one of the following is an endangered plant species of India?
- a. *Rauwolfia serpentina*
 - b. *Santalum album* (Sandal wood)
 - c. *Cycas beddomei*
 - d. All of the
11. What is common to *Lantana*, *Eichhornia* and African catfish?
- a. All are endangered species of India.
 - b. All are key stone species.
 - c. All are mammals found in India.
 - d. All the species are neither threatened nor indigenous species of India.

12. The extinction of passenger pigeon was due to:
- Increased number of predatory birds.
 - Over exploitation by humans.
 - Non-availability of the food.
 - Bird flu virus infection.
13. Which of the following statements is correct?
- Parthenium* is an endemic species of our country.
 - African catfish is not a threat to indigenous catfishes.
 - Steller's sea cow is an extinct animal.
 - Lantana* is popularly known as carrot grass.
14. Among the ecosystem mentioned below, where can one find maximum biodiversity?
- Mangroves
 - Desert
 - Coral reefs
 - Alpine meadows
15. Which of the following forests is known as the '**lungs of the planet Earth**'?
- Tiaga forest
 - Tundra forest
 - Amazon rain forest
 - Rain forests of North East India
16. The active chemical drug reserpine is obtained from:
- Datura*
 - Rauwolfia*
 - Atropa*
 - Papaver*
17. Which of the following group of plants exhibit more species diversity?
- Angiosperms
 - Algae
 - Bryophytes
 - Fungi
18. Which of the below mentioned regions exhibit less seasonal variations?
- Tropics
 - Temperates
 - Alpines
 - Both (a) & (b)

29. The historic convention on Biological Diversity held in Rio de Janeiro in 1992 is known as:
- CITES Convention
 - The Earth Summit
 - G-16 Summit
 - MAB Programme
20. What is common to the techniques (i) *in vitro* fertilisation, (ii) Cryo preservation and (iii) tissue culture?
- All are in situ conservation methods.
 - All are ex situ conservation methods.
 - All require ultra modern equipment and large space.
 - All are methods of conservation of extinct organisms.

VERY SHORT ANSWER TYPE QUESTIONS

- What characteristics make a community stable?
- What could have triggered mass extinctions of species in the past?
- What accounts for the greater ecological diversity of India?
- According to David Tilman, greater the diversity, greater is the primary productivity. Can you think of a very low diversity man-made ecosystem that has high productivity?
- What does 'Red' indicate in the IUCN Red list (2004)?
- Explain as to how protection of biodiversity hot spots alone can reduce up to 30% of the current rate of species extinction.
- What is the difference between endemic and exotic species?
- How does species diversity differ from ecological diversity?
- Why is genetic variation important in the plant *Rauwolfia vomitoria*?
- What is Red Data Book?
- Define gene pool.
- What does the term 'Frugivorous' mean?
- What is the expanded form of IUCN?
- Define the terms (i) Bioprospecting (ii) Endemism

15. What is common to the species shown in figures A and B?



A



B

16. What is common to the species shown in figures A and B?



A



B

SHORT ANSWER TYPE QUESTIONS

- How is the presently occurring species extinction different from the earlier mass extinctions?
- Of the four major causes for the loss of biodiversity (Alien species invasion, habitat loss and fragmentation, over-exploitation and co-extinctions) which according to you is the major cause for the loss of biodiversity? Give reasons in support.
- Discuss one example, based on your day-to-day observations, showing how loss of one species may lead to the extinction of another.
- A species-area curve is drawn by plotting the number of species against the area. How is it that when a very large area is considered the slope is steeper than that for smaller areas?
- Is it possible that productivity and diversity of a natural community remain constant over a time period of, say one hundred years?
- There is greater biodiversity in tropical /subtropical regions than in temperate region. Explain.

7. Why are the conventional methods not suitable for the assessment of biodiversity of bacteria?
8. What criteria should one use in categorizing a species as threatened?
9. What could be the possible explanation for greater vulnerability of amphibians to extinction as compared to other animal groups?
10. How do scientists extrapolate the total number of species on Earth?
11. Humans benefit from diversity of life. Give two examples.
12. List any two major causes other than anthropogenic causes of the loss of biodiversity.
13. What is an endangered species? Give an example of an endangered plant and animal species each?
14. What are sacred groves and their role in biodiversity conservation?
15. Suggest a place where one can go to study coral reefs, mangrove vegetation and estuaries.
16. Is it true that there is more solar energy available in the tropics? Explain briefly.
17. What is co-extinction? Explain with a suitable example?

LONG ANSWER QUESTIONS

1. Elaborate how invasion by an alien species reduces the species diversity of an area.
2. How can you, as an individual, prevent the loss of biodiversity?
3. Can you think of a scientific explanation, besides analogy used by Paul Ehrlich, for the direct relationship between diversity and stability of an ecosystem?
4. Though the conflict between humans and wildlife started with the evolution of man, the intensity of conflict has increased due to the activities of modern man. Justify your answer with suitable examples.
5. What is an ecosystem service? List any four important ecosystem services provided by the natural ecosystems. Are you in favour or against levying a charge on the service provided by the ecosystem?
6. Describe the consumptive use value of biodiversity as food, drugs and medicines, fuel and fiber with suitable examples.

7. Species diversity decreases as we move away from the equator towards the poles. What could be the possible reasons?
8. Explain briefly the 'rivet popper hypothesis' of Paul Ehrlich.
9. The relation between species richness and area for a wide variety of taxa turns out to be a rectangular hyperbola. Give a brief explanation.

© NCERT
not to be republished

CHAPTER 16

ENVIRONMENTAL ISSUES

MULTIPLE-CHOICE QUESTIONS

1. Non-biodegradable pollutants are created by:
 - a. nature
 - b. excessive use of resources
 - c. humans
 - d. natural disasters
2. According to the Central Pollution Control Board, particles that are responsible for causing great harm to human health are of diameter:
 - a. 2.50 micrometers
 - b. 5.00 micrometers
 - c. 10.00 micrometers
 - d. 7.5 micrometers
3. The material generally used for sound proofing of rooms like a recording studio and auditorium, etc. is:
 - a. cotton
 - b. coir
 - c. wood
 - d. styro foam
4. Compressed Natural Gas (CNG) is:
 - a. propane
 - b. methane
 - c. ethane
 - d. butane
5. World's most problematic aquatic weed is:
 - a. *Azolla*
 - b. *Wolffia*
 - c. *Eichornia*
 - d. *Trapa*

6. Which of the following causes biomagnification?
 - a. SO_2
 - b. Mercury
 - c. DDT
 - d. Both b & c

7. The expanded form of DDT is:
 - a. dichloro diphenyl trichloroethane
 - b. dichloro diethyl trichloroethane
 - c. dichloro dipyrydyl trichloroethane
 - d. dichloro diphenyl tetrachloroacetate

8. Which of the following material takes the longest time for biodegradation?
 - a. Cotton
 - b. Paper
 - c. Bone
 - d. Jute

9. Choose the incorrect statement.
 - a. The Montreal protocol is associated with the control of emission of ozone depleting substances
 - b. Methane and carbon dioxide are green house gases
 - c. Dobson units are used to measure oxygen content
 - d. Use of incinerators is crucial to disposal of hospital wastes

10. Among the following which one causes more indoor chemical pollution?
 - a. burning coal
 - b. burning cooking gas
 - c. burning mosquito coil
 - d. room spray

11. The green scum seen in the fresh water bodies is:
 - a. blue green algae
 - b. red algae
 - c. green algae
 - d. both (a) and (c)

12. The loudness of a sound that a person can withstand without discomfort is about
 - a. 150 dB.
 - b. 215 dB.
 - c. 30 dB.
 - d. 80 dB.

13. The major source of noise pollution, world wide is due to:
- office equipment
 - transport system
 - sugar, textile and paper industries
 - oil refineries and thermal power plants.
14. Match correctly the following and choose the correct option
- | | |
|---|---------|
| i. Environment Protection Act | A. 1974 |
| ii. Air Prevention & Control of Pollution Act | B. 1987 |
| iii. Water Act | C. 1986 |
| iv. Amendment of Air Act to include noise | D. 1981 |
- The correct matches is;
- | | |
|---------------------------|---------------------------|
| a. i-C, ii-D, iii-A, iv-B | b. i-A, ii-C, iii-B, iv-D |
| c. i-D, ii-A, iii-B, iv-C | d. I-C, ii-D, iii-B, iv-A |
15. Catalytic converters are fitted into automobiles to reduce emission of harmful gases. Catalytic converters change unburnt hydrocarbons into:
- carbon dioxide and water
 - carbon mono oxide
 - methane
 - carbon dioxide and methane
16. Why is it necessary to remove sulphur from petroleum products?
- To reduce the emission of sulphur dioxide in exhaust fumes
 - To increase efficiency of automobiles engines
 - To use sulphur removed from petroleum for commercial purposes
 - To increase the life span of engine silencers
17. Which one of the following impurities is easiest to remove from wastewater?
- Bacteria
 - Colloids
 - Dissolved solids
 - Suspended solids
18. Which one of the following diseases is not due to contamination of water?
- Hepatitis-B
 - Jaundice
 - Cholera
 - Typhoid

19. Nuisance growth of aquatic plants and bloom-forming algae in natural waters is generally due to high concentrations of:
- carbon
 - sulphur
 - calcium
 - phosphorus
20. Algal blooms impart a distinct colour to water due to:
- their pigments
 - excretion of coloured substances
 - formation of coloured chemicals in water facilitated by physiological degradation of algae.
 - absorption of light by algal cell wall.
21. Match the items in column I and column II and choose the correct option:
- | Column I | Column II |
|---------------------------------|---------------------|
| A. UV | i) Biomagnification |
| B. Biodegradable Organic matter | ii) Eutrophication |
| C. DDT | iii) Snow blindness |
| D. Phosphates | iv) BOD |
- The correct match is:
- A ii, B i, C iv, D iii
 - A iii, B ii, C iv, D i
 - A iii, B iv, C i, D ii
 - A iii, B I, C iv, D i
22. In the textbook you came across Three Mile Island and Chernobyl disasters associated with accidental leakage of radioactive wastes. In India we had Bhopal gas tragedy. It is associated with which of the following?
- CO₂
 - Methyl Iso-Cyanate
 - CFC's
 - Methy Cyanate

VERY SHORT ANSWER TYPE QUESTIONS

- Use of lead-free petrol or diesel is recommended to reduce the pollutants emitted by automobiles. What role does lead play?
- In which year was the Air (Prevention and Control of Pollution) Act amended to include noise as air pollution.
- Name the city in our country where the entire public road transport runs on CNG.

4. It is a common practice to undertake desilting of the overhead water tanks. What is the possible source of silt that gets deposited in the water tanks?
5. What is cultural eutrophication?
6. List any two adverse effects of particulate matter on human health.
7. What is the raw material for polyblend?
8. Blends of polyblend and bitumen, when used, help to increase road life by a factor of three. What is the reason?
9. Mention any two examples of plants used as wind breakers in the agricultural fields.
10. Name an industry which can cause both air and thermal pollution and as well as eutrophication.
11. What is an algal bloom?
12. What do you understand by biomagnification?
13. What are the three major kinds of impurities in domestic wastewater?
14. What is reforestation?
15. What is the best solution for the treatment of electronic wastes?

SHORT ANSWER TYPE QUESTIONS

1. Is it true that carpets and curtains/drapes placed on the floor or wall surfaces can reduce noise level. Explain briefly?
2. What is hybrid vehicle technology?. Explain its advantages with a suitable example?
3. Is it true that if the dissolved oxygen level drops to zero, the water will become septic. Give an example which could lower the dissolved oxygen content of an aquatic body.
4. Name any one green house gas and its possible source of production on a large scale. What are the harmful effects of it?
5. It is a common practice to plant trees and shrubs near the boundary walls of buildings. What purpose do they serve?
6. Why has the National Forest Commission of India recommended a relatively larger forest cover for hills than for plains?
7. How can slash and burn agriculture become environment friendly?

8. What is the main idea behind “Joint Forest Management Concept” introduced by the Government of India?
9. What do you understand by Snow-blindness?
10. How has DDT caused decline in bird population?
11. Observe the figure A and B given below and answer the following questions

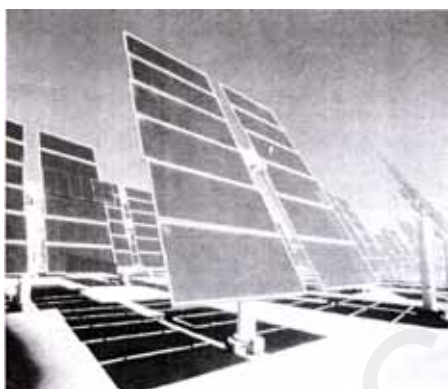

A

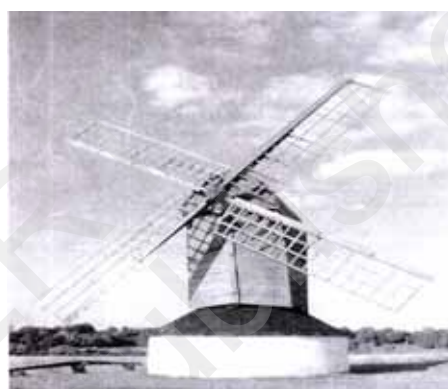

B

- i. The power generation by the above two methods is non-polluting True/False.
- ii. List any two applications of solar energy
- iii. What is a photovoltaic cell?

LONG ANSWER QUESTIONS

1. Write a short note on electronic waste. List the various sources of e- wastes and the problems associated with its disposal.
2. What is organic farming? Discuss the benefits of organic farming as a viable practise in the context of developing nations like India.
3. Water logging and soil salinity are some of the problems that have come in the wake of the Green Revolution. Discuss their causes and adverse effects to the environment.
4. What are multipurpose trees? Give the botanical and local names of any two multipurpose trees known to you and list their uses.

5. What are the basic characteristics of a modern landfill site. List any three and also mention the reasons for their use.

Ans. Characteristics of a modern landfill include:

- i. methods to contain leachate such as lining clay or plastic liners.
 - iii. compaction and covering of the waste to prevent it from being blown by wind.
 - iv. installation of a landfill gas extraction system to extract the gas for use in generation of power.
6. How does an electrostatic precipitator work?
7. Observe figure and answer the following questions.

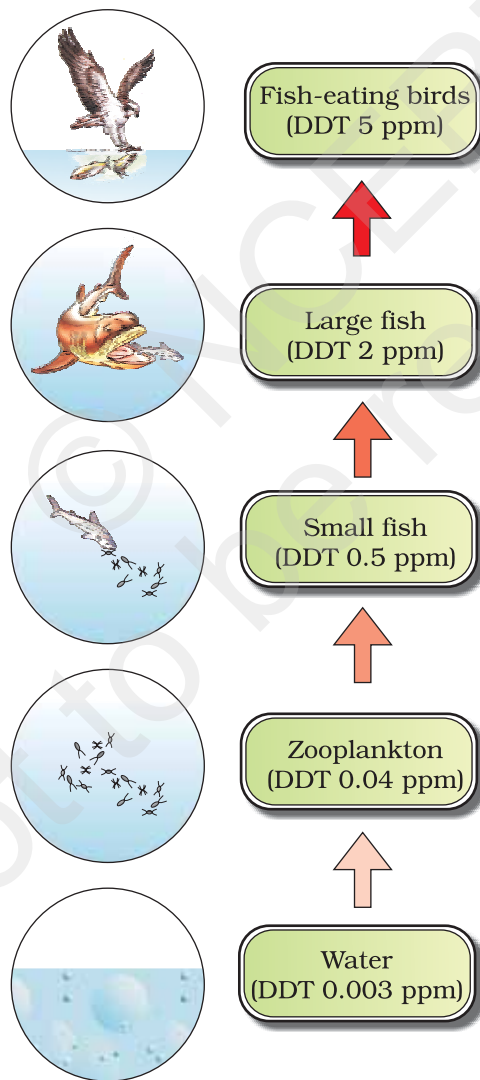

- i. What ecological term is used to describe the DDT accumulation at different trophic levels?
- ii. List any one effect of DDT accumulation on birds
- iii. Will DDT accumulation lead to eutrophication?
- iv. Does it affect the BOD?
- v. Name disease caused by accumulation of any heavy metal.

© NCERT
not to be republished

ANSWERS TO MULTIPLE - CHOICE QUESTIONS

In this chapter answers to all the multiple choice questions covered under sixteen chapters are given as a reference to the learners. They are categorised chapterwise.

CHAPTER 1 : REPRODUCTION IN ORGANISMS

1-c	2-a	3-c	4-b	5-d	6-c
7-b	8-a	9-b	10-b	11-c	12-b
13-c	14-c	15-d	16-b	17-b	18-a

CHAPTER 2 :SEXUAL REPRODUCTION IN FLOWERING PLANTS

1-c	2-c	3-a	4-d	5-d	6-b
7-a	8-b	9-c	10-c	11-a	12-c
13-b	14-a	15-b	16-c	17-c	18-b
19-b	20-a				

CHAPTER 3 : HUMAN REPRODUCTION

1-c	2-b	3-d	4-b	5-a	6-b
7-a	8-b	9-c	10-b	11-c	12-b
13-d	14-b	15-c	16-a	17-a	18-a

CHAPTER 4 : REPRODUCTIVE HEALTH

1-c	2-c	3-a	4-d	5-a	6-a
7-b	8-c	9-b	10-d	11-b	12-c
13-c					

CHAPTER 5 : PRINCIPLE OF INHERITANCE AND VARIATION

1-b	2-a	3-b	4-d	5-d	6-b
7-d	8-b	9-d	10-c	11-a	12-c
13-a	14-b	15-b	16-a	17-d	18-c

CHAPTER 6 : MOLECULAR BASIS OF INHERITANCE

1-b	2-c	3-c	4-c	5-c	6-b
7-d	8-d	9-d	10-b	11-c	12-d
13-b	14-b	15-b	16-b	17-d	18-a
19-d	20-b	21-c	22-d	23-a	24-c
25-b	26-b	27-a	28-a		

CHAPTER 7 : EVOLUTION

1-b	2-c	3-b	4-c	5-b	6-d
7-a	8-c	9-d	10-c	11-a	12-a
13-b	14-c	15-a	16-b	17-d	18-a

CHAPTER 8 : HUMAN HEALTH AND DISEASES

1-c	2-a	3-d	4-d	5-c	6-b
7-a	8-c	9-b	10-c	11-b	12-c
13-a	14-c	15-d	16-b	17-a	18-c
19-c	20-c	21-c	22-d	23-c	

CHAPTER 9 : STRATEGIES FOR ENHANCEMENT IN FOOD PRODUCTION

1-d	2-a	3-d	4-a	5-c	6-c
7-c	8-a	9-b	10-c	11-c	12-a
13-d	14-c	15-d	16-c	17-b	18-c

19-c 20-b 21-c 22-d 23-d 24-b
25-a

CHAPTER 10 : MICROBES IN HUMAN WELFARE

1-c 2-d 3-d 4-c 5-d 6-b
7-d 8-a 9-c 10-b 11-b 12-d
13-d 14-c 15-c 16-a 17-a 18-b

CHAPTER 11 : BIOTECHNOLOGY: PRINCIPLES AND PROCESSES

1-b 2-b 3-a 4-d 5-c 6-d
7-b 8-a 9-c 10-d 11-b 12-c
13-a 14-c 15-c 16-a 17-c 18-c
19-c

CHAPTER 12 : BIOTECHNOLOGY AND ITS APPLICATIONS

1-d 2-c 3-c 4-d 5-c 6-a
7-b 8-d 9-c 10-c 11-c 12-c
13-d 14-b 15-c

CHAPTER 13 : ORGANISMS AND POPULATIONS

1-b 2-c 3-d 4-c 5-c 6-d
7-a 8-c 9-c 10-d 11-b 12-c
13-b 14-c 15-c 16-b 17-c 18-c
19-a 20-d

CHAPTER 14 : ECOSYSTEM

1-c	2-a	3-c	4-b	5-b	6-b
7-c	8-b	9-a	10-b	11-a	12-b
13-d	14-d	15-b	16-c	17-c	18-d
19-b	20-d				

CHAPTER 15 : BIODIVERSITY AND CONSERVATION

1-a	2-c	3-b	4-a	5-d	6-d
7-c	8-c	9-c	10-d	11-d	12-b
13-b	14-c	15-c	16-b	17-d	18-a
19-b	20-b				

CHAPTER 16 : ENVIRONMENTAL ISSUES

1-c	2-a	3-d	4-b	5-c	6-d
7-a	8-c	9-c	10-c	11-d	12-d
13-b	14-a	15-a	16-a	17-d	18-a
19-d	20-a	21-c	22-b		

MODEL ANSWERS TO DESCRIPTIVE QUESTIONS

This chapter deals with model answers to all types of descriptive questions such as Very Short Answer (VSA) type questions, Short Answers (SA) type questions and Long Answer (LA) type questions. The questions are randomly selected from different chapters, the answers are suggestive and written to provide approach and way of presentation.

ANSWERS TO VSA TYPE QUESTIONS

1. Mention two inherent characteristics of *Amoeba* and yeast that enable them to reproduce asexually.

Ans. a. They are unicellular organisms.
 b. They have a very simple body structure.

2. Why do we refer to offspring formed by asexual method of reproduction as clones?

Ans. Offspring formed by asexual reproduction are called clones because they are morphologically and genetically similar to the parent.

3. Although potato tuber is an underground plant part, it is considered as a stem. Give two reasons.

Ans. a. The tuber has nodes and internodes.
 b. Leafy shoots appear from the nodes.

4. Between an annual and a perennial plant, which one has a shorter juvenile phase? Give one reason.

Ans. An annual has a shorter juvenile phase. Since its entire life cycle has to be completed in one growing season, its juvenile phase is shorter.

5. Rearrange the following events of sexual reproduction in the sequence they occur in a flowering plant:

Embryogenesis, Fertilisation, Gametogenesis, Pollination.

Ans. Gametogenesis, Pollination, Fertilisation, Embryogenesis

6. The probability of fruit set in a self-pollinated bisexual flower is far greater than a dioecious plant. Analyse.

7. Name the component cells of the 'egg apparatus' in an embryo sac.

Ans. Two synergids and an egg.

8. Name the part of gynoecium that determines the compatible nature of pollen.

Ans. Stigma.

9. Name the common function that cotyledons and nucellus perform.

Ans. Nourishment.

10. Complete the following flow chart



Ans. Generative cell

11. Indicate the stage where meiosis occurs (1, 2 or 3) in the flow chart.



Ans. 1 = meiosis

12. Name the parts of the gynoecium which develop into fruit and seeds.

Ans. Ovary develops into fruit; ovules develop into seeds.

13. In a case of polyembryony, if an embryo develops from the synergid and another from the nucellus which is haploid and which is diploid?

Ans. Synergid embryo is haploid and nucellar embryo is diploid.

14. Can an unfertilised, apomictic embryo sac give rise to a diploid embryo? If yes, then how?

Ans. Yes, if the embryo develops from the cells of nucellus or integument it will be diploid.

15. Which are the three cells found in a pollen grain when it is shed at the three-celled stage?

Ans. One vegetative cell and two male gametes.

16. Draw the diagram of a mature embryo sac and show its 8-nucleate, 7-celled nature. Label the diagram.

Ans.

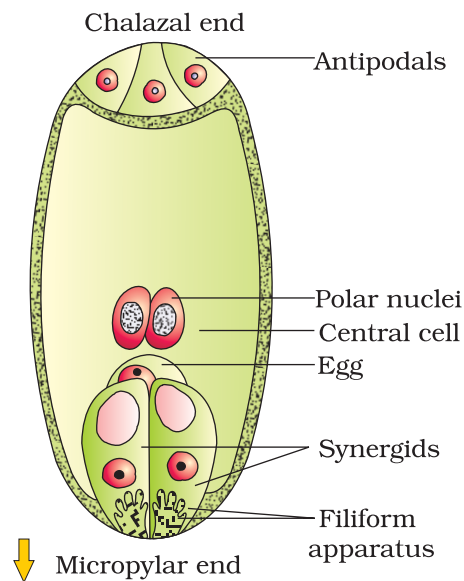

17. Which is the triploid tissue in a fertilised ovule? How is the triploid condition achieved?

Ans. The triploid tissue in the ovule is the endosperm. Its triploid condition is attained due to the fusion of two polar nuclei and one nucleus of male gamete (also referred to as triple fusion).

18. Is pollination and fertilisation necessary in apomixis? Give reasons.

Ans. No, they are not necessary. Apomixis is actually an alternative to sexual reproduction although the female sexual apparatus is used in the process. In apomicts, embryos can develop directly from the nucellus or synergid or egg. Therefore, there is no need for either pollination or fertilisation.

19. Given below are the stages in human reproduction. Write them in correct sequential order.

Insemination, Gametogenesis, Fertilisation, Parturition, Gestation, Implantation

Ans. Gametogenesis, Insemination, Fertilisation, Implantation, Gestation, Parturition.

20. What is the role of cervix of the human female system in reproduction?

Ans. Cervix helps in regulating the passage of sperms into the uterus and forms the birth canal to facilitate parturition.

21. Menstrual cycles are absent during pregnancy. Why?

Ans. The high levels of progesterone and estrogens during pregnancy suppress the gonadotropins which is required for the development of new follicles. Therefore, a new cycle cannot be initiated.

22. Female reproductive organs and associated functions are given below in column A and B. Fill in the blank boxes.

Column A

Ovaries

Oviduct

B

Vagina

Column B

Ovulation

A

Pregnancy

Birth

Ans. **A** — Fertilisation

B — Uterus

23. During reproduction, the chromosome number ($2n$) reduces to half (n) in the gametes and again resume the original number ($2n$) in the offspring, what are the processes through which these events take place?

Ans. Halving of chromosomal number takes place during gametogenesis and regaining the $2n$ number occur as a result of fertilisation.

24. Mention the essential of LH surge during menstrual cycle.

Ans. LH surge is essential for the events leading to ovulation.

25. Reproductive health refers only to healthy reproductive functions. Comment.

Ans. Reproductive health refers to a total well-being in all aspects of reproduction i.e., physical, behavioural, psychological, social and physiological.

26. Comment on the RCH programme of the government to improve the reproductive health of the people.

Ans. Creating public awareness regarding reproduction related aspects and providing facilities to build up a healthy society with added emphasis on the health of mother and child are the basic aims of the RCH programmes.

27. Males in whom testes fail to descend to the scrotum are generally infertile. Why?

Ans. If the testes fail to descend to the scrotum, gametogenesis could be inhibited, the process of spermatogenesis require a marginally lesser ambient temperature than that in the abdominal cavity.

28. A progeny of F_1 , is crossed with the homozygous recessive parent. What is this cross called? Work out how is it useful?

Ans. When a progeny of F_1 is crossed with the homozygous recessive parent, it is called test cross. Such a cross is useful to determine the genotype of an unknown i.e., whether it is heterozygous, or homozygous dominant for the trait.

29. A pedigree chart given below, present a particular generation which shows a trait irrespective of sexes (i.e., present in both male and female). Neither of the parents of the particular generation shows the trait. Draw your conclusion on the basis of the pedigree.

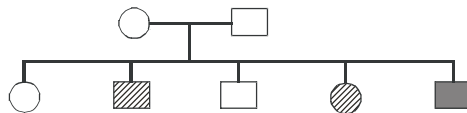

Ans. The trait is autosome linked and recessive in nature. Both the parents are carrier (i.e. heterozygous) hence among offspring few show the trait irrespective of sex. The other offsprings are either normal or carrier.

30. In order to obtain the F_1 generation, Mendel pollinated a true-breeding, say, tall plant with a true-breeding dwarf plant. But for getting the F_2 generation, he simply self-pollinated the tall F_1 plants. Why?

Ans. Genotype of 50% of the offspring would resemble one parent and the rest the other parent. All the F_1 offsprings of the cross are heterozygous so allowing self pollination is sufficient to raise F_2 offspring. Also he intended to understand the inheritance of the selected trait over generations.

31. "Genes contain the information that is required to express a particular trait." Explain.

Ans. The genes present in an organism show a particular trait by way of forming certain product. This is facilitated by the process of transcription and translation (according to central dogma of genetics)

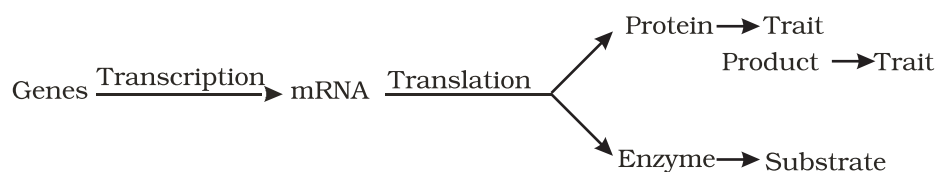

32. How are alleles of particular gene different? Explain its significance.

Ans. Alleles of a particular gene differ from each other on the basis of certain changes (i.e., mutations) in the genetic material (segment of DNA or RNA). Different alleles of a gene increases the variability or variation among the organisms.

33. In monohybrid cross of red and white flower, Mendel got only red flower. On setting the F_1 plants having red flower he got both plants with red and white flower. Explain the basis of using RR and rr symbols to represent the genotype of plants of parental generation.

Ans. On crossing red and white flower only red colour flower appeared in the F_1 generation. But the white colour flower again appear in the F_2 generation which is raised out of the F_1 individuals only. Mendel reasoned that there is a factor of each and every character. Accordingly, there has to be one factor(R) for red flower and other one factor (r) for white flower. In case, an organism possess only one copy of the gene then the possibility of reappearance of white flower in the F_2 generation of the given cross is not there. Also the ratio (3:1 of red and white) indicates that each organism must possess two copies of a particular gene.

34. For the expression of traits “Genes provide only the potentiality and the environment provides the opportunity”. Comment, on the veracity of the statement.

Ans. Hint:

$$\begin{array}{ccc} \text{Phenotype} & = & \text{Genotype} & + & \text{Environment} \\ \text{(Trait)} & & \text{(potentiality)} & & \text{(opportunity)} \end{array}$$

35. A, B,D are three independently assorting genes with their recessive alleles a, b, d respectively. A cross was made between individuals of Aa bb DD genotype with aa bb dd. Explain the type of genotypes of the offspring produced.

Ans. The given cross is Aa bb dd X aa bb dd
Accordingly the type of offspring produced would be

Aa bb DD	X	aa bb dd
↓		↓
		(i) abd
($\frac{1}{2}$) A b D		($\frac{1}{2}$) Aa bb Dd
($\frac{1}{2}$) a b D		($\frac{1}{2}$) aa bb Dd

36. Sometimes cattle or even human beings give birth to their young ones that have extremely different sets of organs like limbs/position of eye(s) etc. Why?

Ans. There is a disturbance in co-ordinated regulation of expression of sets of genes associated with organ development.

37. In a nucleus, the number of RNA nucleoside triphosphates is 10 times more than the number of DNA nucleoside triphosphates, still only DNA nucleotides are added during the DNA replication, and not the RNA nucleotides. Why?

Ans. DNA polymerase is highly specific to recognise only deoxy ribonucleoside triphosphates. Therefore it cannot hold RNA nucleotides.

38. Name indicating their functions, a few additional enzymes, other than DNA polymerase and ligase, that are involved in the replication of DNA with high degree of processivity and accuracy.

Ans. (i) helicase – opens the helix
 (ii) topoisomerases – removes the supercoiling of DNA
 (iii) Primase: synthesises RNA primer
 (iv) Telomerase: to synthesises the DNA of telomeric end of chromosomes.

39. When we say 'simpler organisms' or 'complex organisms' what are we referring to?

Ans. When we say simple or complex organisms we are talking in terms of evolutionary history of an organism. A simple organism is considered to be primitive and has simple thallus organisation. The level of complexity of metabolism is also low. On the other hand a complex organism refers to a more evolved form forming higher levels of structural and functional complexities. They are believed to have arisen from simple organisms.

40. How do we compute the age of a fossil?

Ans. To compute the age of a fossil, we use radiocarbon dating.

41. In a certain population, the frequency of three genotypes is as follows:

Genotypes:	BB	Bb	bb
frequency:	22%	62%	16%

What is the likely frequency of B and b alleles?

Ans. Frequency of *B* allele = all of *BB* + $\frac{1}{2}$ of *Bb* = 22+31 = 53% frequency of *b* allele = all of *bb* + $\frac{1}{2}$ of *Bb* = 16 + 31 = 47%

42. Among the five factors that are known to effect Hardy-Weinberg equilibrium, three factors are gene flow, genetic drift and genetic recombination. What are the other two factors?

- Ans. Natural selection and mutation.
43. By what latin name the first human-like being, the homonid was known?
- Ans. *Homo habilis*.
44. Among *Ramapithecus*, *Australopithecines* and *Homo habilis* - who probably did not eat meat?
- Ans. *Homo habilis*.
45. The immune system of a person is suppressed. In the ELISA test, he was found positive to a pathogen.
- Name the disease the patient is suffering from.
 - What is the causative organism?
 - Which cells of the body are affected by the pathogen?
- Ans. a. Acquired Immuno Deficiency Syndrome (AIDS)
b. Human Immuno deficiency virus (HIV)
c. Helper T-lymphocytes (TH)
46. What would happen to immune system, if thymus gland is removed from the body of a person?
- Ans. Thymus is the primary lymphoid organ. In thymus gland, immature lymphocytes differentiate into antigen-sensitive lymphocytes. If thymus gland is removed from the body of a person, his immune system becomes weak. As a result the person's body becomes prone to infectious diseases.
47. Many microbial pathogens enter the gut of humans along with food. What are the preventive barriers to protect the body from such pathogens? What type of immunity do you observe in this case?
- Ans. (i) The mucus coating of the epithelium lining of the gut helps in trapping microbes entering the body.
(ii) Saliva in the mouth and hydrochloric acid in gastric juice secreted by stomach prevent microbial growth. This type of immunity is innate immunity.
48. What are interferons? How do interferons check infection of new cells?
- Ans. Interferons are natural proteins produced by the cells of immune system in response to foreign agents such as viruses, tumor cells and parasites and protect non-infected cells from further infection.
Interferons inhibit the viral replication within host cells, activate natural killer cells and macrophages, increases antigen presentation to lymphocytes, and induce the resistance of host cells to viral infection. When the antigen is presented to matching T-cells and B-cells, these cells multiply and remove the foreign substance.

50. If a regular dose of drugs or alcohol is not provided to an addicted person, he shows some withdrawal symptoms. List any four such withdrawal symptoms.

Ans. The withdrawal symptoms are:
 a. Anxiety
 b. Shakiness
 c. Nausea
 d. Sweating

51. Millions of chickens were killed in West Bengal, Orissa and Maharashtra recently. What was the reason?

Ans. Millions of chicken were killed (culled) in West Bengal, Orissa and Maharashtra because they were found to be infected with H5N1 virus the causal organism of Bird Flu.

52. In animal husbandry, if two closely related animals are mated for a few generations, it results in loss of fertility and vigour. Why is it so?

Ans. The phenomenon being referred to is called 'Inbreeding Depression' and results in loss of fertility and vigour. This happens because the recessive alleles tend to get together and express harmful effects in the progeny.

53. Do you know of a man made cereal? Trace, how it was developed?

Ans. Triticale. It was developed by crossing *Triticum aestivum* (wheat and *Secale cereale* (rye)

54. Fill in the blanks

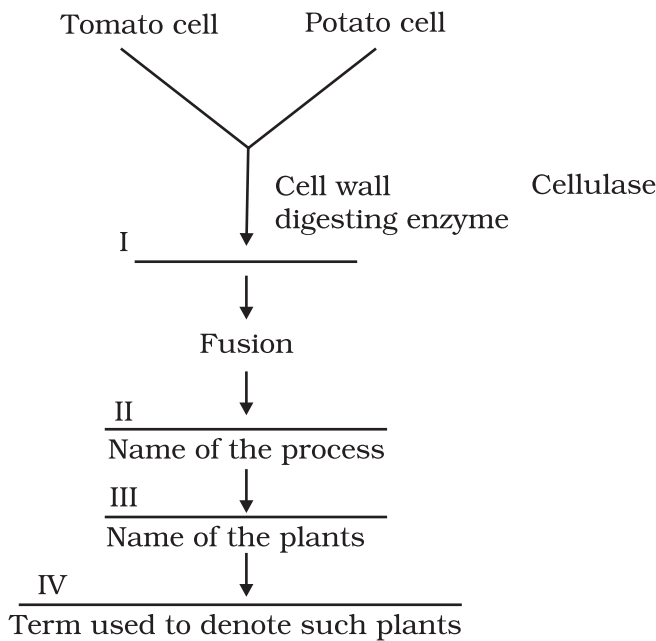

- Ans. I Cellulase; II Somatic hybridization; III Potato; IV Somatic hybrid
55. What is meant by 'hidden hunger'?
- Ans. Consumption of food deficient in nutrients particularly, micronutrients, proteins and vitamins is called hidden hunger
56. What is protoplast fusion?
- Ans. The ability of protoplasts obtained from two different cells to fuse and form a hybrid protoplast is called protoplast fusion.
57. Name a microbe used for statin production. How do statins lower blood cholesterol level?
- Ans. *Monascus purpureus* statins lower blood cholesterol level by competitively inhibiting the enzyme responsible for synthesis of cholesterol.
58. What are nucleopolyhedroviruses being used for now a days?
- Ans. Nucleopolyhedroviruses are used for the biological control of insect pesto.
59. What are biofertilisers?
- Ans. Biofertilisers are organisms that enrich the nutrients in the soil.
60. What would have happened if antibiotics were not discovered?
- Ans. If antibiotics were not discovered bacterial and fungal diseases would not have been controllable.
61. Why is distillation required for producing certain alcoholic drinks?
- Ans. Distillation increases the alcohol content in alcoholic drinks.
62. Give any two microbes that are useful in biotechnology.
- Ans. *E.coli* and *Saccharomyces cerevisiae*
63. What is Chakravarty bug? Give its scientific name and its application?
- Ans. Chakravarty Bug is a super bug of *Pseudomonas* with multiple plasmid. They are helpful in removing oil spills.
64. Name any genetically modified crop.
- Ans. Bt cotton.
65. List any two industrially important enzymes.
- Ans. Lipase, Amylase.
66. Name an immune suppressive agent?
- Ans. Cyclosporin.

67. Give an example of a rod shaped virus.

Ans. Tobacco mosaic virus.

68. For producing a recombinant protein (for therapeutic purpose) in large scale, which vector would you choose – a low copy number or high-copy number?

Ans: High-copy number, because higher the copy number of vector plasmid, higher the copy number of gene and consequently, protein coded by the gene is produced in high amount.

69. Would you like to choose an exonuclease enzyme while producing a recombinant DNA molecule?

Ans: No, as exonuclease acts on the free ends of linear DNA molecule. Therefore, instead of producing DNA fragments with sticky ends, it will shorten or completely degrade the DNA fragment containing the gene of interest, and the circular plasmid (vector) will not get cut as it lacks free ends.

70. Restriction enzymes present in the cloning site of a vector should not have more than one recognition site. Comment.

Ans. If the restriction enzymes have more than one recognition site in a vector, then the vector itself will get fragmented on treatment with the restriction enzyme.

71. What does 'competent' refer to in competent cells used in transformation?

Ans: Competent means bacterial cells, on treatment with CaCl_2 , are made capable of taking up foreign DNA.

72. What is the significance of adding proteases at the time of isolation of genetic material (DNA).

Ans: Role of proteases is to degrade the proteins present inside a cell (from which DNA is being isolated). If the proteins are not removed from DNA preparation then they could interfere with any downstream treatment of DNA (such as action of restriction endonuclease, DNA ligase etc).

73. While doing a PCR, 'denaturation' step is missed. What will be its effect on the process?

Ans: If denaturation of double-stranded DNA does not take place, then primers will not be able to anneal to the template, no extension will take place, hence no amplification will occur.

74. Name a recombinant vaccine that is currently being used in vaccination program?

Ans: Hepatitis B recombinant vaccine-Engerix is used for vaccination of hepatitis-virus.

75. Expand GMO. How is it different from a hybrid?

Ans. GMO stands for Genetically Modified Organism. It differs from a hybrid because in a hybrid, cross is done between total genomes of two species or strains, where as in a GMO, foreign gene(s) is introduced in the organism, and is usually maintained as extra-chromosomal entity or is integrated into the genome of the organism.

76. Differentiate between diagnostics and therapeutics. Give one example under each category.

Ans. A diagnostic technique helps us to identify a disease. Example: ELISA to test for HIV. A therapeutic agent on the other hand helps in the treatment of a disease. Example: Antibiotics for bacterial infections.

77. Many proteins are secreted in their inactive form. This is also true of many toxic proteins produced by micro organisms. Explain how the mechanism is useful for the organism producing the toxin?

Ans. Many proteins including certain toxins are secreted in their inactive form. They get activated, only when exposed to a specific trigger (pH, temperature etc.). It is advantageous to the bacteria producing it because the bacteria does not get killed due to the action of protein.

78. Name the first transgenic cow. Which gene was introduced in this cow?

Ans. Rosie was the name of the first transgenic cow. Gene for human alpha lactalbumin was introduced in its gene, which made the milk nutritionally richer.

79. PCR is a useful tool for early diagnosis of an infectious disease. Comment.

Ans. PCR is a very sensitive technique which enables the specific amplification of desired DNA from a limited amount of DNA template. Hence, it can detect the presence of an infectious organism in the infected patient at an early stage of infection (even before the infectious organism has multiplied to large number).

80. What is GEAC and what are its objectives?

Ans. GEAC (Genetic Energy Approval Committee) is an Indian government organisation. Its objective are to:

- a. examine the validity of GM (Genetic modification of organism) research.
- b. inspect the safety of introducing GM for public services.

81. For which variety of Indian rice, patent was filed by a USA Company?

Ans. Indian Basmati was crossed with semi-dwarf variety and was claimed as a new variety for which the patent was filed by a USA company.

82. Species that tolerate narrow range temperature are called _____.
- Ans. (Stenothermic)
83. What are Eurythermic species?
- Ans. Species that tolerate wide range of temperature are called Eurythermic species.
84. Species that tolerate wide range of salinity are called _____
- Ans. (Euryhaline)
85. What is Mycorrhiza?
- Ans. Mycorrhiza is a symbiotic association between a fungus and the roots of higher plants.
86. What would be the growth pattern, when the resources are unlimited.
- Ans. Exponential.
87. Give a suitable example for commensalism.
- Ans. Cattle egret and grazing cattle.
88. Name an organism found as secondary carnivore in an aquatic ecosystem in your area.
- Ans. Catfish / water snake etc.
89. What does the base tier of the ecological pyramid represent?
- Ans. Producers
90. Under what conditions would a particular stage in the process of succession revert back to an earlier stage?
- Ans. Natural or human induced disturbances like fire, deforestation etc.
91. Arrange the following as you observe in vertical stratification of a forest- Grass, Shrubby plants, Teak, Amaranths.
- Ans. Grass, Amaranths, Shrubby plants, Teak
92. Name an omnivore which occurs in both grazing food chain and the decomposer food chain.
- Ans. Sparrow / crow
93. Justify the pitcher plant as a producer.
- Ans. It is chlorophyllous and is thus capable of photosynthesis.
94. Name any two organisms which occupy more than one trophic level in an ecosystem.

- Ans. Man and sparrow etc.
95. Climax stage is achieved quickly in secondary succession as compared to primary succession. Why?
- Ans. The rate of succession is much faster in secondary succession as the substratum (soil) is already present as compared to primary succession where the process starts from a bare area (rock).
96. Among the crustose, foliose and fruticose lichens which one is a pioneer species?
- Ans. Crustose lichens.
97. Why is the rate of assimilation of energy at the herbivore level called secondary productivity?
- Ans. It is because the biomass available to the consumer for consumption is a resultant of the primary productivity from plants.
98. What is common to earthworm, mushroom, soil mites and dung beetle in an ecosystem.
- Ans. They are all detritivores i.e., decomposing organisms which feed on dead remains of plants and animals.
99. According to David Tilman greater the diversity greater is the primary productivity. Can you think of a very low diversity man-made ecosystem that has high productivity.
- Ans. Agricultural fields like wheat field / paddy field which are also examples of monoculture practices.
100. What is the difference between endemic and exotic species?
- Ans. Endemic species are restricted native to a particular geographical region. Exotic species are species which are introduced from other geographical regions into an area.
101. Why is genetic variation important in the plant *Rauwolfia vomitoria*?
- Ans. Genetic variation affects the production of the drug principle reserpine in the medicinal plant *Rauwolfia*.
102. What is the Red Data Book?
- Ans. The Red data book is a compilation of data on species threatened with extinction, maintained by IUCN.
103. What is the expanded form of IUCN?
- Ans. International Union for Conservation of Nature and Natural Resources.

104. What is common to both the species shown in figures A and B?



A



B

Ans. Both are invasive weed species

105. What is common to the species shown in figures A and B?



A



B

Ans. Both are examples for Keystone species

106. In which year was the Air (Prevention and control of pollution) Act amended to include noise as air pollution.

Ans. 1987.

107. Name the city in which the entire public road transport runs on CNG.

Ans. Delhi.

108. It is a common practice to undertake desilting of the overhead water tanks. What is the possible source of silt that gets deposited in the water tanks.

Ans. The soil particles carried by water from the source of supply.

109. What is the raw material for polyblend?

Ans. Plastic waste.

110. Name an industry which can cause air pollution, thermal pollution and eutrophication.

Ans. Fertiliser factory.

ANSWERS TO SA TYPE QUESTIONS

1. In haploid organisms that undergo sexual reproduction, name the stage in the life cycle when meiosis occurs. Give reasons for your answer.
Ans. Meiosis takes place during the post-zygotic stage. Since the organism is haploid, meiosis cannot occur during gametogenesis.
2. The number of taxa exhibiting asexual reproduction is drastically reduced in the higher plants (angiosperms) and higher animals (vertebrates) as compared with lower groups of plants and animals. Analyse the possible reasons for this situation.
Ans. Both angiosperms and vertebrates have a more complex structural organisation. They have evolved very efficient mechanisms of sexual reproduction. Since asexual reproduction does not create new genetic pools in the offspring and consequently hampers their adaptability to external conditions, these groups have resorted to reproduction by the sexual method.
3. With which type of reproduction do we associate the reduction division? Analyse the reasons for it.
Ans. Reduction division (meiosis) is associated with sexual reproduction. The reasons for this are:
 - a. Since sexual reproduction involves the fusion of two types of gametes (male and female), they must have a haploid number of chromosomes.
 - b. The cell (meiocyte) which gives rise to gametes often has a diploid number of chromosomes and it is only by reducing the number by half that we can get haploid gametes.
 - c. Reduction division also ensures maintenance of constancy of chromosome number from generation to generation.
4. 'Fertilisation is not an obligatory event for fruit production in certain plants'. Explain the statement.
Ans. Yes, it is observed in parthenocarpic fruits. The 'seedless fruits' that are available in the market such as pomegranate, grapes etc., are in fact good examples. Flowers of these plants are sprayed by a growth hormone that induces fruit development even though fertilisation has not occurred. The ovules of such fruits, however, fail to develop into seeds.

5. Draw the sketches of a zoospore and conidium. Mention two dissimilarities between them and atleast one feature common to both structures.

Ans.



Zoospore

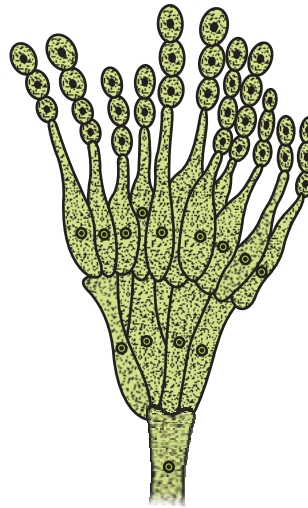

Conidiumphore

Dissimilarities

Zoospore

1. Flagellated
2. Formed inside a sporangium (endogenously)

Conidium

1. Non-flagellated
2. Formed at the tip of conidiophores (exogenously)

The common feature is that both are asexual reproductive structures.

6. Given below are the events that are observed in an artificial hybridization programme. Arrange them in the correct sequential order in which they are followed in the hybridization programme.

(a) re-bagging; (b) selection of parents; (c) bagging; (d) dusting the pollen on stigma; (e) emasculation; (f) collection of pollen from male parent.

Ans. b; e; c; f; d and a.

7. Why does the zygote begin to divide only after the division of primary endosperm cell?

Ans. The zygote needs nourishment during its development. As the mature, fertilised embryo sac offers very little nourishment to the zygote, the PEC divides and generates the endosperm tissue which nourishes the zygote. Hence, the zygote always divides after division of PEC.

8. The generative cell of a 2-celled pollen divides in the pollen tube but not in a 3-celled pollen. Give reasons.

Ans. In a 3-celled pollen, the generative cell has already divided and formed 2 male gametes. Hence, it will not divide again in the pollen tube. Since in a 2-celled pollen, the generative cell has not divided, it divides in the pollen tube.

9. Women experiences two major events in their life time one at menarche and the second at menopause, mention the characteristics of both the events.

Ans. Menarche represents the beginning of menstrual cycle which is an indication of attainment of sexual maturity. Menopause, on the other hand, refers to the cessation of menstruation which inturn means stoppage of gamete production i.e., it marks the end of reproductive/ fertile life of the female.

9. Corpus luteum in pregnancy has a long life. However, if fertilisation does not take place it remains active only for 10-12 days . Why?

Ans. This is because of a neural signal given by the maternal endometrium to its hypothalamus in presence of a zygote to sustain the gonadotropin (LH) secretion, so as to maintain the corpus luteum as long as the embryo remains there. In the absence of a zygote, therefore, the corpus luteum can not be maintained longer.

10. Placenta has endocrine function. Does it have other functions? Explain.

Ans. Placenta facilitates the supply of oxygen and nutrients to the embryo. It also removes CO₂ excretory wastes produced by embryo.

11. What are the events taking place in the ovary and uterus during follicular phase of the menstrual cycle.

Ans.

1. The primary follicle grow and become fully mature graafian follicles.
2. Secretion of estrogen hormone.
3. Endometrium of uterus regenerates through proliferation.

12. Given below is a flow chart showing ovarian changes during menstrual cycle. Fill in the spaces with the hormonal factor/s responsible for the events shown.

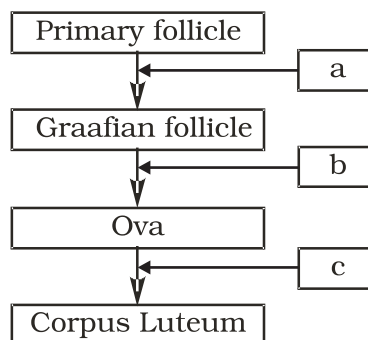

Ans. a – FSH and estrogen; b-LH; C-progesterone

14. In GIFT, gametes are transferred to the fallopian tube. Can gametes be transferred to the uterus to achieve the same result? Explain.

Ans. The uterine environment is not congenial for the survival of the gamete. If, directly transferred to the uterus they will undergo degeneration or could be phagocytosed and hence viable zygote would not be formed.

15. Briefly explain IVF and ET. What are the conditions in which these methods are advised?

Ans. IVF and ET refers to In vitro Fertilisation and Embryo Transfer. Gametes from the male and female are collected hygienically and induced to fuse in the laboratory set up under simulated conditions. The zygote formed is collected and is introduced into the uterine region of a host or surrogate mother at an appropriate time (secretory phase). Early embryos (upto 8 cell) are generally transferred to the fallopian tube whereas embryos with more than 8 cells are transferred to the uterine.

16. All reproductive tract infections (RTIs) are STDs, but all STDs are not RTIs- Justify with example.

Ans. Among the common STs-gonorrhoea, syphilis, genital herpes, chlamydia, hepatitis-B, AIDS etc., hepatitis-B, and AIDS are not infections of the reproductive organs though their mode of transmission could be through sexual contact also. All other diseases are transmitted through sexual contact and are also infections of the reproductive tract.

17. In a mendelian monohybrid cross the F₂ generation shows identical genotypic and phenotypic ratios. What does it tell us about the nature of alleles involved? Justify your answer.

Ans. In a monohybrid cross, starting with parents which homozygous dominant and homozygous recessive, F₁ would be heterozygous for the trait and would express the dominant allele. But in case of incomplete dominance, a monohybrid cross shows the result as follows.

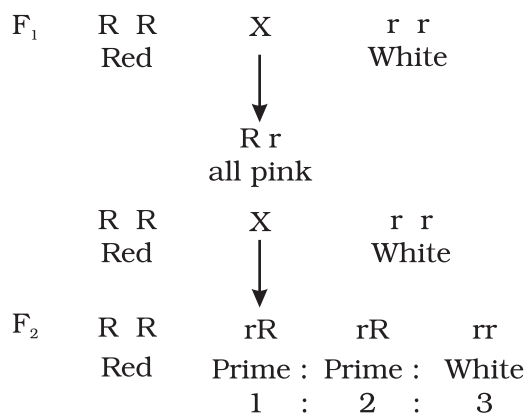

Phenotypic ratio

Genotypic ratio

Here the genotypic and phenotypic ratios are the same. So, we can conclude that when genotypic and phenotypic ratios are the same, the alleles show incomplete dominance.

18. What is Down's syndrome? Give its symptoms and cause. Why is it that the chances of having a child with Down's syndrome increases if the age of the mother exceeds forty years?

Ans. Down's syndrome is a human genetic disorder caused due to trisomy of chromosome no. 21. Such individuals are aneuploid and have 47 chromosomes. $(2n + 1)$ The symptoms include mental retardation, growth abnormalities, constantly open mouth, dwarfness etc. The reason for the disorder is the non-disjunction (failure to separate) of homologous chromosome of pair 21 during meiotic division in the ovum. The chances of having a child with Down's syndrome increase with the age of the mother (+ 40) because ova are present in females. since their birth and therefore older cells are more prone to chromosomal non-disjunction because of various physico-chemical exposures during the mother's life-time.

19. What are the characteristic features of a true-breeding line?

Ans. A true-breeding line for a trait is one that, has undergone continuous self-pollination or brother-sister mating, showing a stability in the inheritance of the trait for several generations.

20. In peas, tallness is dominant over dwarfness, and red colour of flowers is dominant over the white colour. When a tall plant bearing red flowers was pollinated by a dwarf plant bearing white flowers, the different phenotypic groups were obtained in the progeny in numbers mentioned against them.

Tall, Red = 138

Tall, White = 132

Dwarf, Red = 136

Dwarf, White = 128

Mention the genotypes of the two parents and of the types of four offspring.

Ans. The result shows that the four types of offspring are in a ratio of 1:1:1:1. Such a result is observed in a test-cross progeny of a dihybrid cross.

The cross can be represented as:

Tall & Red (Tt Rr) × Dwarf & white (ttrr)

offsprings		tr		
Tt Rr – Tall, Red	TR	TtRr	Tall	Red
Tt rr – Tall, White	Tr	Ttrr	Tall	White
Tt Rr – dwarf, red	tR	ttRr	dwarf	Red
tt rr – dwarf, white.	tr	ttrr	dwarf	white

21. Why is the frequency of red-green colour blindness is many times higher in males than that in the females?

Ans. For becoming colourblind, the female must have the allele for it in both her X-chromosomes; but males develop colourblindness when their sole x-chromosome has the allele for it.

22. If a father and son are both defective in red-green colour vision, is it likely that the son inherited the trait from his father? Comment.

Ans. Gene for colourblindness is X-chromosome linked, and sons receive their sole from their mother, not from their father. Male-to-male inheritances is not possible for X-linked traits in humans. In the given case the mother of the child must be a carrier. (heterozygous) for colour blindness gene.

23. Retrovirus do not follow central dogma. Comment.

Ans: Genetic material of retrovirus is RNA. At the time of synthesis of protein, RNA is 'reverse transcribed' to its complementary DNA first, which is opposite to the central dogma. Hence, retrovirus are not known to follow central dogma.

24. In an experiment, DNA is treated with a compound which tends to place itself amongst the stacks of nitrogenous base pairs. As a result of which, the distance between two consecutive base increases, from 0.34nm to 0.44 nm. Calculate the length of DNA double helix (which has 2×10^9 bp) in the presence of saturating amount of this compound.

Ans. $2 \times 10^9 \times 0.44 \times 10^{-9}$ /bp

25. What would happen if histones were to be mutated and made rich in amino acids aspartic acid and glutamic acid in place of basic amino acids such as lysine and arginine?

Ans. If histone proteins were rich in acidic amino acids instead of basic amino acids then they may not have any role in DNA packaging in eukaryotes as DNA is also negatively charged molecule. The packaging of DNA around the nucleosome would not happen. Consequently, the chromatin fibre would not be formed.

26. Recall the experiment done by Frederick Griffith. If RNA, instead of DNA was the genetic material, would the heat killed strain of *strepts* have transformed the R-strain into virulent strain? Explain your answer.

Ans: RNA is more labile and prone to degradation (owing to the presence of 2' OH group in its ribose). Hence heat-killed S-strain may not have retained its ability to transform the R-strain into virulent form if RNA was its genetic material.

27. You are repeating the Hershey-Chase experiment and are provided with two isotopes: ^{32}P and ^{15}N (in place of ^{35}S in the original experiment). How do you expect your results to be different?

Ans. Use of ^{15}N will be inappropriate because method of detection of ^{35}P and ^{15}N is different (^{32}P being a radioactive isotope while ^{15}N is not radioactive but is the heavier isotope of Nitrogen). Even if ^{15}N was radioactive then its presence would have been detected both inside the cell (^{15}N incorporated as nitrogenous base in DNA) as well as in the supernatant because ^{15}N would also get incorporated in amino group of amino acids in proteins). Hence the use of ^{15}N would not give any conclusive results.

28. There is only one possible sequence of amino acids when deduced from a given nucleotides. But multiple nucleotide sequences can be deduced from a single amino acid sequence. Explain this phenomena.

Ans. Some amino acids are coded by more than one codon (known as degeneracy of codons), hence on deducing a nucleotide sequence from an amino acid sequence, multiple nucleotide sequence will be obtained.

For e.g., Ile has three codons: AUU, AUC, AUA hence a dipeptide Met-Ile can have the following nucleotide sequence:

- (i) AUG - AUU
- (ii) AUG - AUC
- (iii) AUG - AUA

and if, we deduce amino acid sequence from the above nucleotide sequences, all the three will code for Met-Ile

29. A single base mutation in a gene may not 'always' result in loss or gain of function. Do you think the statement is correct? Defend your answer.

Ans. The statement is correct. Because of degeneracy of codons, mutations at third base of codon, usually does not result into any change in phenotype. This is called silent mutations.

30. A low level of expression of lac operon occurs at all the time. Can you explain the logic behind this phenomena.

Ans: In the complete absence of expression of lac operon, permease will not be synthesised which is essential for transport of lactose from medium into the cells. And if lactose cannot be transported into the cell, then it cannot act as inducers hence, cannot relieve the lac operon from its repressed state.

31. Would it be appropriate to use DNA probes such as VNTR in DNA fingerprinting of a bacteriophage?

Ans. Bacteriophage does not have repetitive sequences such as VNTRs in its genome as its genome is very small and has all the coding sequence. DNA fingerprinting is not done for phages.

32. During *in vitro* synthesis of DNA, a researcher used 2', 3' - dideoxy cytidine triphosphate as raw nucleotide in place of 2'-deoxy cytidine triphosphate other conditions remaining as standard. Will further polymerisation of DNA continue upto the end or not? Explain.

Ans. Further polymerisation would not occur, as the 3' OH on sugar is not there to add a new nucleotide for forming ester bond.

33. What background information did Watson and Crick had available with them for developing a model of DNA? What was their own contribution?

Ans. Wastson and Crick had the following informations which helped them to develop a model of DNA.

- (i) Chargaffs' Law suggesting $A = T$, and $C = G$.
- (ii) Wilkins and Rosalind Franklin's work on DNA crystal's X-ray diffraction studies about DNA's physical structure.
- (iii) Watson and crick proposed
 - a. How complementary bases may pair
 - b. Semi conservative replication and
 - c. Mutation through tautomerism.

34. What are the functions of (i) methylated guanasine cap, (ii) poly-A "tail" in a mature on RNA?

Ans. Methylated Guanine cap helps in binding of mRNA to smaller ribosomal sub-unit during initiation of translation. Poly- A tail provides longevity to mRNA's life. Tail length and longevity of mRNA are positively correlated.

35. Do you think that the alternate splicing of exons may enable a structural gene to code for several isoproteins from one and the same gene? If yes, how? If not, why so?

Ans. Functional mRNA of structural genes need not always include all of its exons. This alternate splicing of exons is sex-specific, tissue-specific, and even developmental stage-specific. By such alternate splicing of exons, a single gene may encode for several isoproteins and/or proteins of similar class. In absence of such a kind of splicing, there should have been new genes for every protein/isoprotein. Such an extravagancy has been avoided in natural phenomena by way of alternate splicing.

36. Comment on the utility of variability in number of tandem repeats during DNA finger printing.

Ans. Tandemness in repeats provides many copies of the sequence for finger-printing, and variability in nitrogen base sequence in them. Being individual-specific, this proves to be useful in the process of DNA fingerprinting.

37. Scientists claim that nascent oxygen is toxic to aerobic life forms. What are the reasons.

Ans. Nascent oxygen is highly reactive. It can react readily with different kinds of molecules, including DNA, proteins present in the cells of aerobic life forms. This may lead to mutations and undesirable metabolic changes.

38. While creation and presence of variation is directionless, natural selection is directional as it is in the context of adaptation. Comment.

Ans. Creation and variation occur in a sexually reproducing population as a result of crossing over during meiosis and random fusion of gametes. It is however the organisms that are selected over a period of time which are determined by the environmental conditions. In other words, the environment provides the direction with respect to adaptations so that the organisms are more and more fit in terms of survival.

39. Gene flow occurs through generations. and can occur across language barriers in humans. If we have a technique of measuring specific allele frequencies in different population of the world, can we not predict human migratory patterns in pre-history and history? Do you agree or disagree? Provide explanation to your answer.

Ans. Yes, I agree. Gene flow occurs through generations. By studying specific allele frequencies, we can predict the human migratory patterns in pre-history and history. Studies have used specific genes/chromosomes/mitochondrial DNA to trace the evolutionary history and migratory patterns of humans. (The project is known as the Human Genographics Project).

40. When we say "survival of the fittest", does it mean that

- a. Those which are fit only survive, or
- b. Those that survive are called fit

Comment.

Ans. Those individuals which survive and reproduce in their respective environment are called fit.

41. Enumerate three most characteristic criteria for designating a Mendelian population.

Ans. Population must be sufficiently large with potentialities for free flow of genetic material among individuals (through sexual reproduction). Migration should either be nil or negligible.

42. "Migration may enhance or blurr the effects of selection". Comment.

Ans. Migration may cause enrichment of the gene pool of such alleles that are being selected for, or anull the effects of selection through replishment of alleles that were selected against by nature.

43. From which plant are Cannabinoids obtained? Name any two Cannabinoids. Which part of the body is effected by consuming these substances?

Ans. Cannabinoids are obtained from the inflorescence of the plant *Cannabis sativa*. Marijuana, hashish, charas, ganja are some Cannabinoids. These chemicals interact with Cannabinoid receptors of the body, mainly present in the brain. Cardiovascular system is effected adversely.

44. In the metropolitan cities of India, many children are suffering from allergy/asthma. What are the main causes of this problem. Give some symptoms of allergic reactions.

Ans. Allergy is the exaggerated response of the immune system of certain antigens present in the environment. In metropolitan cities life style is responsible in lowering of immunity and sensitivity to allergens. More polluted environment increases the chances of allergy in children. Some symptoms of allergic reactions are sneezing, watery eyes, running nose and difficulty in breathing.

45. What is the basic principle of vaccination? How do vaccines prevent microbial infections? Name the organism from which hepatitis B vaccine is produced.

Ans. The principle of vaccination is based on the property of 'memory' of the immune system. In vaccination, a preparation of antigenic proteins of pathogens or inactivated/live but weakened pathogens is introduced into the body. The antigens generate the primary immune response by producing antibodies. The vaccines also generate the memory B-cells and T-cells. When the vaccinated person is attacked by the same pathogens, the existing memory B-cells or T-cells recognises the antigen quickly and overwhelm the invaders with massive production of lymphocytes and antibodies. Hepatitis B vaccine is produced from yeast.

46. What is Cancer? How is a Cancer cell different from normal cell? How do normal cells attain Cancerous nature?

Ans. An abnormal and uncontrolled division of cells is termed as Cancer.

The Cancerous cells are different from the normal cells in the following ways.

Cancer Cells	Normal Cells
1. Cancer cells divide in an uncontrolled manner.	1. Normal cells divide in a controlled manner.
2. The cells do not show contact inhibition	2. The cells show contact inhibition.
3. Life span is indefinite	3. Life span is definite.

In our body, the growth and differentiation of cells is highly controlled and regulated. The normal cells show a property called contact inhibition.

The surrounding cells inhibits uncontrolled growth and division of cells. The normal cells lose this property and become cancerous cells giving rise to masses of cells called tumors. Transformation of normal cells into cancerous cells is induced by some physical, chemical and biological agents (carcinogens).

47. A person shows strong unusual hypersensitive reactions when exposed to certain substances present in the air. Identify the condition. Name the cells responsible for such reactions. What precaution should be taken to avoid such reactions.

Ans. Allergy. Mast Cells are responsible for such reactions.

To avoid such reactions following precautions must be taken.

- (i) The use of drugs like antihistamine, adrenalin and steroids quickly reduce the symptoms of allergy.
 - (ii) Avoid contact with substances to which a person is hypersensitive.
48. Life style diseases are increasing alarmingly in India. We are also dealing with large scale malnutrition in the population. Is there any method by which we can address both these problems?

Ans. The answer to address both these problems is called biofortification. This area looks at improving food quality with respect to protein, oil, vitamin, micro nutrient and mineral content. The oils need to be rich in omega 3 fatty acids which are good for heart. Similarly, proteins should have more of lysine and tryptophan (essential amino acids). Many varieties of maize, carrots and spinach have been released which fulfill the above criteria.

49. How can we improve the success rate of fertilisation during artificial insemination in animal husbandry programmes?

Ans. The technology is called MOET or Multiple Ovulation Embryo Transfer. During the procedure, a cow is given hormonal treatment so that more than one ovule (6-8 eggs) is produced per cycle. After mating or artificial insemination the embryos at 8-32 celled state are transferred to different surrogate mother cows. The method has been successfully used for cattle, sheep, buffalo etc.

50. What is meant by germplasm collection? What are its benefits?

Ans. The collection of all the diverse alleles of all the genes of a crop plant is called germplasm collection. It is of great benefits in plant breeding programmes as it offers, to the breeders, the entire of genes and alleles and the characteristics which they express. The breeder selects the most favourable characters of a particular gene and manipulates its transfer to a desirable parent.

51. Name the three improved characteristics of wheat that helped India achieve green revolution.

- Ans.
- i. Semi-dwarf nature
 - ii. Quick yielding feature
 - iii. High yielding feature
 - iv. Disease resistant feature

52. Suggest two features of plants that will prevent insect and pest infestation

- Ans.
- i. increasing hair growth on aerial parts of plants.
 - ii. Rendering the flowers nectar less.
 - iii. Enabling plants to secrete insect killing chemicals (toxins)

53. What are the physical barriers of a cell in the protoplast fusion experiment? How are the barriers overcome?

- Ans. Cell wall is the most important physical barrier in such experiments. This can be overcome by treatment with enzymes like cellulase and pectinase which have the ability to digest the cell wall and liberate the naked protoplast surrounded only by the cell membrane.

54. Give two examples of biofortified crops. What benefits do they offer to the society?

- Ans. Maize, wheat, rice, bathua, spinach, pulses have biofortified varieties. Maize hybrids have twice the amount of amino acids, fortified wheat variety has high protein content, fortified rice has high quantity of iron. Consumption of such biofortified foods will enrich the nutritive value of our common foods and will vastly improve public health. Instead of consuming different food items for obtaining different nutrients, if 2 or 3 nutrients can be incorporated into a single crop, it offers enormous benefits to human beings and may even help cover some several nutrient deficiency disorders latent in our country.

55. How has the bacterium *Bacillus thuringiensis* helped us in controlling caterpillars of insect pests?

- Ans. *Bacillus thuringiensis* products are endotoxin which when ingested and released in the gut of the larvae of insect pest disrupts the insect gut lining thereby killing them.

56. How do mycorrhizal fungi help the plants harbouring them?

- Ans. The mycorrhizal fungi absorb phosphorus from the soil and transfer them to the host cells. They also impart resistance to host plants against root pathogens. They also help plant tolerate salinity and draught.

57. How was penicillin discovered?

Ans. Penicillin was an accidental discovery. Sir Alexander Fleming observed that in unwashed culture plates of *Staphylococcus*, a mould *Penicillium* was growing. This mould inhibited the growth of *Staphylococcus*. Later the antibiotic *Penicillin* was isolated from this fungus.

58. What is the chemical nature of biogas. Name an organism which is known to be employed in biogas?

Ans. The chemical nature of Biogas is methane, CO₂ & H₂. *Methanobacteria*, a type of methanogen is employed for biogas production.

59. What is a broad spectrum antibiotic? Name a broad spectrum antibiotic and source organism.

Ans. A broad spectrum antibiotic is one which can inhibit the growth of both G⁺ & G⁻ bacteria.

60. What do you understand by gene cloning?

Ans. Gene cloning refers to a process in which a gene of interest is ligated to a vector. The recombinant DNA thus produced is introduced in a host cell by transformation. Each cell gets one DNA molecule and when the transformed cell grows to a bacterial colony, each cell in the colony has a copy of the gene. This is precisely gene cloning.

61. A wine maker and a molecular biologist who has developed a recombinant vaccine, both claim themselves to be biotechnologists. Who in your opinion is right?

Ans. Both. As biotechnology is a very wide area which deals with techniques of using a 'natural' organism (or its parts) as well as genetically modified organisms to produce products and processes useful for mankind. A wine maker employs a strain of yeast to produce wine by fermentation (a natural phenomenon), while the molecular biologist has cloned a gene for the antigen (that is used as a vaccine) in an organism which allows the production of the antigen in large amounts.

62. You have created a recombinant DNA molecule by ligating a gene to a plasmid vector. By mistake, your friend adds exonuclease enzyme to the tube containing the recombinant DNA. How will your experiment be affected as you plan to go for transformation now?

Ans: The experiment will not likely be affected as the recombinant DNA molecule is circular and closed, with no free ends. Hence, it will not be a substrate for exonuclease enzyme which removes nucleotides from the free ends of DNA.

63. The restriction enzymes that are used in the construction of recombinant DNA molecules are endonucleases which cut the DNA at 'specific-recognition sequences'. What would be the disadvantage if they would not cut the DNA at specific-recognition sequences?

Ans: If the restriction enzymes would cut DNA at random sites instead of at specific sites, then the DNA fragments obtained will not have 'sticky ends'. In the absence of sticky ends, construction of recombinant DNA molecule would not be possible.

64. A plasmid DNA and a linear DNA (both of the same size) have one site for a restriction endonuclease. When cut and separated on agarose gel electrophoresis, plasmid shows one DNA band while linear DNA shows two fragments. Explain.

Ans: It is because plasmid is a circular DNA molecule. When cut with enzyme, it becomes linear but does not get fragmented. Whereas, a linear DNA molecule gets cut into two fragments. Hence, a single DNA band is observed for plasmid while two DNA bands are observed for linear DNA in agarose gel.

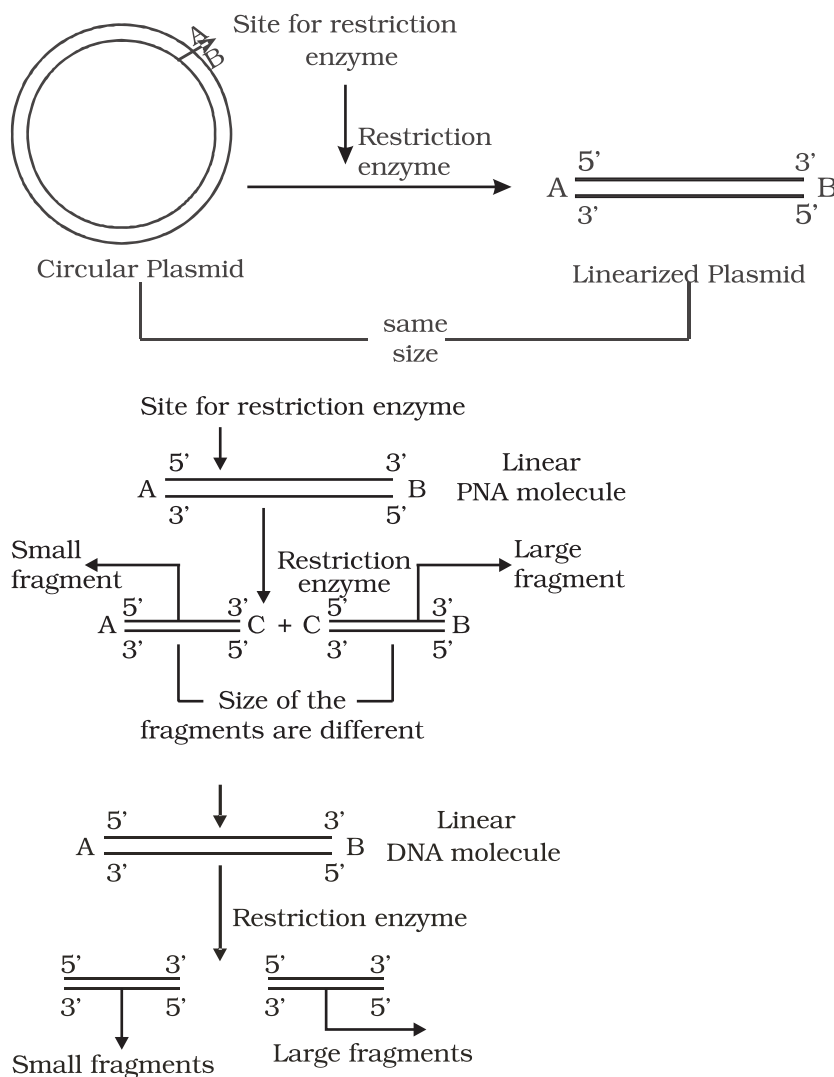

65. How do you visualise DNA on an agarose gel?

Ans: A compound called Ethidium Bromide stains DNA, which on irradiating with Ultra Violet, fluoresce gives orange light. Hence, DNA fragments appear as orange band in the presence of Ethidium Bromide and UV.

66. You have chosen a plasmid as vector for cloning your gene. However this vector plasmid lacks a selectable marker. How would it affect your experiment?

Ans: In a gene cloning experiment, first a recombinant DNA molecule is constructed, where the gene of interest is ligated to the vector, [The step would not be affected] and introduced inside the host cell (transformation). Since, not all the cells get transformed with the recombinant / plasmid DNA, in the absence of selectable marker, it will be difficult to distinguish between transformants and non-transformant, because role of selectable marker is in the selection of transformants.

67. A mixture of fragmented DNA was electrophoresed in agarose gel. After staining the gel with ethidium bromide, no DNA bands were observed. What could be the reason?

Ans. The reasons are as follows:

- (i) DNA sample that was loaded on the gel may have got contaminated with nuclease (exo-or endo-or both) and completely degraded.
- (ii) Electrodes were put in opposite orientation in the gel assembly that is anode towards the wells (where DNA sample is loaded). Since DNA molecules are negatively charged, they move towards anode and hence move out of the gel instead of moving into the matrix of gel.
- iii) Ethidium bromide was not added at all or was not added in sufficient concentration and so DNA was not visible.

68. Describe the role of CaCl_2 in preparation of competent cells?

Ans. CaCl_2 is known to increase the efficiency of DNA uptake to produce transformed bacterial cells. The divalent Ca^{+2} ions supposedly create transient pores on the bacterial cell wall by which the entry of foreign DNA is facilitated into the bacterial cells.

69. What would happen when you grow a recombinant in a bioreactor but forget to add antibiotic to the medium in which the recombinant is growing.

Ans. In the absence of antibiotic, there will be no pressure on recombinants to retain the plasmid (containing the gene of your interest). Since, maintaining a high copy number of plasmids is a metabolic burden to the microbial cells, will thus tend to lose the plasmid.

70. Gene expression can be controlled with the help of RNA molecule. Explain the method with an example.

Ans. Gene expression can be controlled by using RNA molecule. The technology is called RNA interference or RNAi. It is used to block the expression of certain genes and also referred to as gene silencing. During this process a complementary RNA to the mRNA being produced by the gene is introduced into the cell. This RNA binds to the mRNA making it double stranded and therefore stops translation. Resistance to nematode *Meloidogyne incognita* in tomato has been achieved by this method.

71. Define the terms Antigen and Antibody. Name any two diagnostic kits based upon them.

Ans. An antigen is a foreign substance that elicits the formation of an antibody. Antibody is a protein that is synthesised in response to an antigen. Antigen and antibody show high degree of specificity in binding each other. Two diagnostic kits based on antigen-antibody interaction are.

- a. ELISA for HIV.
- b. Pregnancy test kits.

72. ELISA technique is based on the principles of antigen and antibody interaction. Can this technique be used in the molecular diagnosis of a genetic disorder, such as phenylketonuria?

Ans. Yes. One can use antibody against the enzyme (that is responsible for the metabolism of phenylalanine) to develop ELISA based diagnostic technique. The patient where the enzyme protein is absent would give negative result in ELISA when compared to normal individual.

73. How is a mature, functional insulin hormone different from its pro-hormone form?

Ans. Mature functional insulin is obtained by processing of pro-hormone which contains extra peptide called C-peptide. This C-peptide is removed during maturation of pro-insulin to insulin.

74. Gene therapy is an attempt to correct a genetic defect by providing a normal gene into the individual. By this the normal function can be restored. Alternate method would be to provide the gene product (protein/enzyme) known as enzyme replacement therapy, which would also restore the function. Which in your opinion is a better option? Give reason for your answer.

Ans. Gene therapy would be a better option because it has the potential to completely cure the patient. It is because the correct gene once introduced in the patient, can continue to produce the correct protein/enzyme. Enzyme therapy does not offer permanent cure as it needs to be given to the patient on regular basis. It is also more expensive.

75. Transgenic animals are the animals in which a foreign gene is expressed. Such animals can be used to study the fundamental biological process/ phenomenon as well as for producing products useful for mankind. Give one example for each type.

Ans. Study basic biological process- how gene are regulated, how they affect the normal functions of the body and its development. Transgenic cow, Rosie is the example for the second category.

76. When a foreign DNA is introduced in to an organism, how it is maintained in the host and how it is transferred to the progeny of the organism?

Ans. Foreign gene is usually ligated to a plasmid vector and introduced in the host. As plasmid replicates, and makes multiple copies of itself, so does the foreign gene gets replicated and its copies are made. When the host organism divides, its progeny also receives the plasmid DNA containing the foreign gene.

77. Bt cotton is resistant to pest, such as lepidopteron, dipterans and coleopterans. Is Bt cotton resistant to other pests as well?

Ans. Bt cotton is made resistant to only certain specific taxa of pests. It is quite likely that in future, some other pests may infest this Bt cotton plants. It is similar immunisation against small-pox which does not provide immunity against other pathogens like those that cause cholera, typhoid etc.

78. Why are coral reefs not found from West Bengal to Andhra Pradesh but found in Tamil Nadu on the east coast of India?

Ans. High salinity, optimal temperature and less siltation are essential to colonise corals. If siltation and fresh water inflow are very high, the corals don't colonise. In contrast when the siltation and fresh water inflow by the rivers are very less, the coral do colonise.

79. In a sea shore, the benthic animals live in sandy, muddy and rocky substrata and accordingly developed the following adaptations. Find the suitable substratum against each adaptation.

- a. Burrowing _____
- b. Building cubes _____
- c. Holdfasts / peduncle _____

Ans a. Sandy, b. Muddy, c. Rocky

80. Plants living in the water are called hydrophytes, Those living in the areas with water scarcity are called xerophytes; and the plants living in saline waters are called halophytes. Write the type of plant against the following examples.

- a. *Salvinia* _____

- b. *Opuntia* _____
- c. *Rhizophora* _____
- d. *Mangifera* _____

Ans. a. Hydrophyte, b. Xerophyte, c. Halophyte, d. Mesophyte

81. In a pond, we see plants which are free-floating; rooted-submerged; rooted emergent; rooted with floating leaves; Write the type of plant against the following examples.

- a. *Hydrilla* _____
- b. *Typha* _____
- c. *Nymphaea* _____
- d. *Lemna* _____
- e. *Vallisnaria* _____

Ans. a. submerged, b. Rooted emergent, c. Rooted with floating leaves, d. free - floating, e. Rooted Submerged

82. Number of individuals of a population in a habitat per unit area is called density and density is measured in different units. Write the unit of measurement against the following:

- a. Bacteria
- b. Grass
- c. Banyan
- d. Deer
- e. Fish

Ans. a. Nos. / Vol; b. Coverage / area; c. Biomass / area; d. Nos. / area; e. Wt. / area

83. What is a tree line?

Ans. When we go up the altitude, beyond a particular height no trees are found and the vegetation comprises only of shrubs and herbs. The altitude beyond which no tree is seen is known as tree line.

84. Is it Possible to achieve 'zero population growth rate? If yes, what kind of age pyramid is obtained?

Ans. Yes. An inverted bell shaped age pyramid is obtained. The young of pre reproductive age group individuals are less in number and both pre- reproductive and reproductive stages are in the same level.

85. The number of trophic levels in an ecosystem are limited. Comment.

Ans. In a food chain, only 10% of the total amount of energy is passed on to the next trophic level from the previous trophic level. So, there is a decrease in the amount of energy available at the successive trophic levels. As we

move higher up in the food chain the amount of energy diminishes to a level at which it cannot sustain any trophic level, thereby limiting the number of trophic levels.

86. What could be the reason for the fast rate of decomposition in the tropics?

Ans. The rate of decomposition is regulated by climatic factors like temperature and soil moisture as they have an effect on the activities of soil microbes. The tropics with its hot and humid climatic condition provides an environment which is ideal for the microbes to speed up the process of decomposition.

87. Flow of energy through various trophic levels in an ecosystem is unidirectional and non cyclic. Explain.

Ans. The energy from the sun reaches the food chain through the primary producers (plants). This energy is passed on through successive trophic levels in the food chain. The energy transfer in the food chain follows the 10 percent law where in only 10% of the energy is transferred from one trophic level to the next successively. So, the movement of energy is only in one direction from lower to higher trophic level.

88. Apart from plants and animals, microbes form a permanent biotic component in an ecosystem. While plants have been referred to as autotrophs and animals as heterotrophs, what are microbes referred to as? How do these microbes fulfil their energy requirements?

Ans. Microbes are referred to as heterotrophs and saprotrophs. They fulfil their energy requirement by feeding on dead remains of plants and animals through the process of decomposition.

89. Primary productivity varies from ecosystem to ecosystem. Explain?

Ans. Primary productivity varies from ecosystem to ecosystem because it depends on the plant species inhabiting the area and their photosynthetic activity. It also depends on various environmental factors.

90. Sometimes due to biotic/abiotic factor the community remains in a particular seral stage (Pre climax) without reaching the climax. Do you agree with this statement. If, yes give a suitable example.

Ans. It is true that any change in the abiotic/biotic factor will arrest a particular seral stage leading to a pre-climax condition before the climax stage is achieved. This can happen in cases of forest fires, landslides, changes in soil characteristics, increase in herbivore population leading to overgrazing.

91. What is an incomplete ecosystem? Explain with the help of a suitable example.

Ans. An ecosystem is a functional unit with biotic and abiotic factors interacting with one another resulting in a physical structure. Absence of any component will make an ecosystem incomplete as it will hinder the functioning of the ecosystem. Exemplar of such an ecosystem can be a fish tank or deep aphotic zone of the oceans where producers are absent.

92. What are the shortcomings of ecological pyramids in the study of ecosystem?

Ans. The ecological pyramid assumes a simple food chain and does not accommodate food webs. Thereby, it does not take into account the fact that species may belong to two or more trophic levels at a time. Also saprophytes despite their vital role in ecosystem are given no place in the ecological pyramids.

93. The rate of decomposition of detritus is affected by the abiotic factors like availability of oxygen, pH of the soil substratum, temperature etc. Discuss.

Ans. The decomposition of detritus is due to activities of micro organisms. The rate of growth of microbes is affected by temperature. The pH of substratum affects the composition of microbes (acidophiles / basophiles) which degrade the dead organic matter. If oxygen is present, aerobic degradation occurs. In the absence of oxygen anaerobiosis sets in and there will be incomplete degradation. Also, the degradation is due to activity of exo enzymes secreted by the microbes and the activity of enzyme is affected by factors such as temperature etc.

94. How is the presently occurring species extinction different from the earlier mass extinctions?

Ans. Species extinction occurring at present is due to anthropogenic causes where as the earlier extinction was due to natural causes.

95. Discuss one example, based on your day-to-day observations, showing how loss of one species may lead to extinction of another.

Ans. In case a species (x) becomes extinct, the plant and animal species (M, N, O, Z) associated within an obligatory way also become extinct. For example.

- (i) When a fish species which is a host for a number of parasites becomes extinct the parasite species which are uniquely dependent on the host fish will also become extinct.
- (ii) The insects may be polyphagous (feed on more than one plant species) or monophagous (feed on only one particular plant species) in nature. The monophagous insect species are valuable and may become extinct if the plant species upon which it feeds becomes extinct.

96. Why are conventional methods not suitable for the assessment of biodiversity of bacteria?

Ans. Many bacteria are not culturable under normal conditions in the laboratory. This becomes a problem in studying their morphological, biochemical and other characterisations which are useful for their assessment.

97. How do scientists extrapolate the total number of species on Earth?

Ans. Scientists make a statistical comparison of the temperate-tropical species richness of an exhaustively studied group of insects and extrapolate this ratio to other groups of animals and plants to come up with a gross estimate of the total number of species on earth.

98. Is it true that there is more solar energy available in the tropics? Explain briefly.

Ans. As one moves from the equator to the polar regions, the length of the day decreases and the length of the night increases. The length of day and night are the same at the equator.

99. What is hybrid vehicle technology. Explain the advantages with a suitable example?

Ans. Vehicles running on dual mode like petrol and CNG are hybrid vehicle. As CNG is a green fuel there is conservation of fossil fuels and reduction in the environmental pollution.

100. Is it true that if the dissolved oxygen level drops to zero the water will become septic. Give an example which could lower the dissolved oxygen content of an aquatic body.

Ans. Yes, the water become septic if the dissolved oxygen drops to zero. Organic pollution (biodegradable) is an example.

101. Name any one of the green house gases and its possible source of production on a large scale. What are the harmful effects of it?

Ans. CO₂ and Methane. CO₂ levels are increasing due to burning of fossil fuels, leading to Global Warming.

102. It is a common practice to plant trees and shrubs near the boundary walls of buildings. What purpose do they serve.

Ans. The plants growing near the boundary wall act as barriers for sound pollution and act as dust catchers.

ANSWERS TO LA TYPE QUESTIONS

1. Do all the gametes formed from a parent organism have the same genetic composition? Are the DNA in identical copies of the parental genome? Analyse the situation with the background of gametogenesis and provide suitable explanation.

Ans. The gametes of a parent do not have the same genetic composition because they do not have identical copies of DNA. In the pachytene and diplotene stages of meiosis I, the phenomenon of crossing over and chiasma formation take place between homologous chromosomes. This shifts segments of DNA from one chromatid to another (homologous chromosomes) in a random manner resulting in several new combinations of DNA sequences. As a result, when meiotic division is completed, gametes possess DNA with varying degree of variations.

2. Although sexual reproduction is a long drawn, energy-intensive complex form of reproduction, many groups of organisms in Kingdom Animalia and Plantae prefer this mode of reproduction. Give at least three reasons for this.

Ans. a. Sexual reproduction brings about variation in the offspring.
b. Since gamete formation is preceded by meiosis, genetic recombination occurring during crossing over (meiosis-I), leads to a great deal of variation in the DNA of gametes.
c. The organism has better chances survival in a changing environment.

3. Rose plants produce large, attractive bisexual flowers but they seldom produce fruits. On the other hand Lady's finger produces plenty of fruits. Analyse the reasons for failure of fruit formation in rose.

Ans. Failure of fruit formation in rose may be due to several reasons. Some of the likely reasons are:

- a. Rose plants may not produce viable pollen.
b. Rose plants may not have functional egg.
c. Rose plants may have abortive ovules.
d. Being hybrids, the meiotic process may be abnormal resulting in non-viable gametes.
e. There may be self-incompatibility.
f. There may be internal barriers for pollen tube growth and/or fertilisation.
4. Starting with the zygote, draw the diagrams of the different stages of embryo development in a dicot.

Ans.

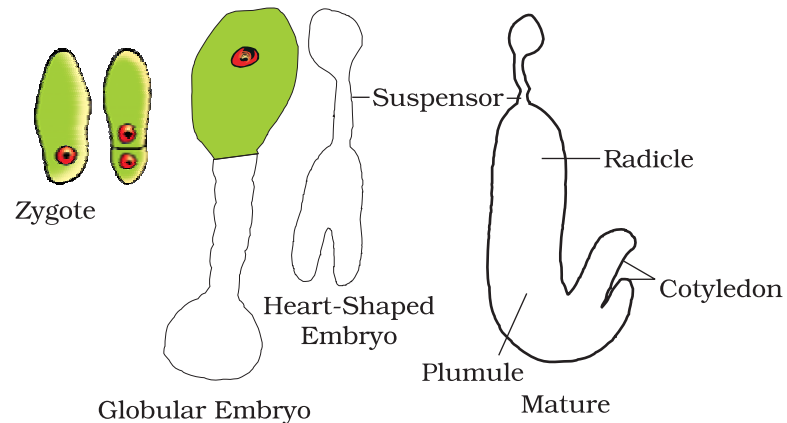

5. Embryo sacs of some apomictic species appear normal but contain diploid cells. Suggest a suitable explanation for the condition.

Ans. It is true that many apomicts possess normal looking embryo sacs. The only possibility of the embryo sac possessing diploid cells is due to failure of meiotic division at the megaspore mother cell stage. Since, the megaspore mother cell has a diploid nucleus, if it undergoes mitosis instead of meiosis, all the resulting nuclei and cells will be diploid in nature.

6. What role does pituitary gonadotrophins play during follicular and ovulatory phases of menstrual cycle and also explain the shift in steroidal secretions.

Ans. Menstrual cycle is regulated by hypothalamus through the pituitary gland. At the end of menstrual phase, the pituitary FSH gradually increases resulting in follicular development within the ovaries. As the follicles mature, Estrogen secretion increases resulting in a surge in (FSH and LH). The surge of LH is responsible for ovulation. LH also gonadotropins induces luteinisation. This leading to the formation of corpus luteum. Corpus luteum secretes progesterone and source estrogen which help in maintaining the interine endometrium for implantation.

7. Meiotic division during oogenesis is different from that in spermatogenesis. Explain how and why?

Ans. Unequal cytoplasmic diversion of the oocyte is to ensure the retention of bulk of cytoplasm in one cell, instead of sharing it with two. It has to provide nourishment for the developing embryo during early stages, so it is essential to retain as much cytoplasmic materials it could in a single daughter cell.

8. Enumerate and describe any five reasons for introducing sex-education to school-going children.

Ans. Proper information about reproductive organs-physiology and its functioning; discourage myths and misconceptions about sex-related aspects; knowledge about safe and hygienic sexual practices; adolescence and related changes, prevention of STDs, AIDs etc.

9. a. In humans, males are heterogametic and females are homogametic, Explain. Are there any examples where males are homogametic and females are heterogametic?
 b. Also describe as to, who determines the sex of an unborn child? Mention whether temperature has a role in sex determination.

Ans.

- (a) The term homogametic and heterogametic refer to the organism depending upon whether all the gametes contain one type of sex chromosome (Homo = same) or two different types of sex chromosomes (Hetero = different) Humans show XX/XY type of sex determination i.e. Females contain 2 copies of X chromosome and males contain 1 X & 1 Y chromosome. Therefore, ova produced by females contain the same sex chromosome i.e. X. On the other hand the sperms contain 2 different types of chromosomes i.e. 50% sperms have X and 50% have Y chromosome open from half the autosomes (Meiosis) Therefore, the sperms are different with respect to the composition of sex chromosome. In case of humans, females are considered to be homogametic while males are heterogametic. Yes, there are examples where males are homogametic and females are heterogametic. In some birds the mode of sex determination is denoted by ZZ (males) and ZW (females).
 (b) As a rule the heterogametic organism determines the sex of the unborn child. In case of humans, since males are heterogametic it is the father and not the mother who decides the sex of the child. In some animals like crocodiles, lower temperature favour hatching of female offsprings and higher temperatures lead to hatching of male offsprings.

10. A normal visioned woman, whose father is colour blind, marries a normal visioned man. What would be the probability of her (a) sons (b) daughters to the colour blind? Explain with the help of pedigree chart.

Ans.

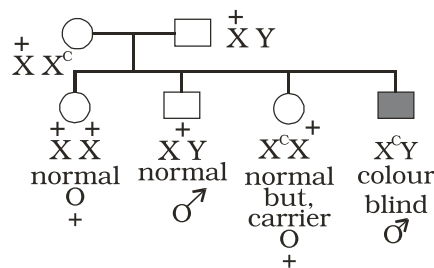

All daughters normal visioned; 50% of sons are likely to be colour blind.

11. You have studied the story of pepper moths in England. Had the industries been removed, what impact could it have had on the moth population? Discuss.

Ans. In the population of Peppermoth, 2 variants were already existing in the population, the black and the grey. In the absence of Industrialisation the grey moths were prevalent because they blended very well with the lichen and moss covered trees camouflage and the predators cannot spot them. The Black ones were easily spotted and killed by predators and therefore were fewer in numbers. With Industrilisation the stems got covered with black soot. This provided better camouflage to the black variant and their number increased. If the industries had been removed the population of black moths would have declined because as stated earlier they would have been spotted better by predators and therefore be eaten more frequently.

12. Represent schematically the life cycle of malarial parasite.

Ans.

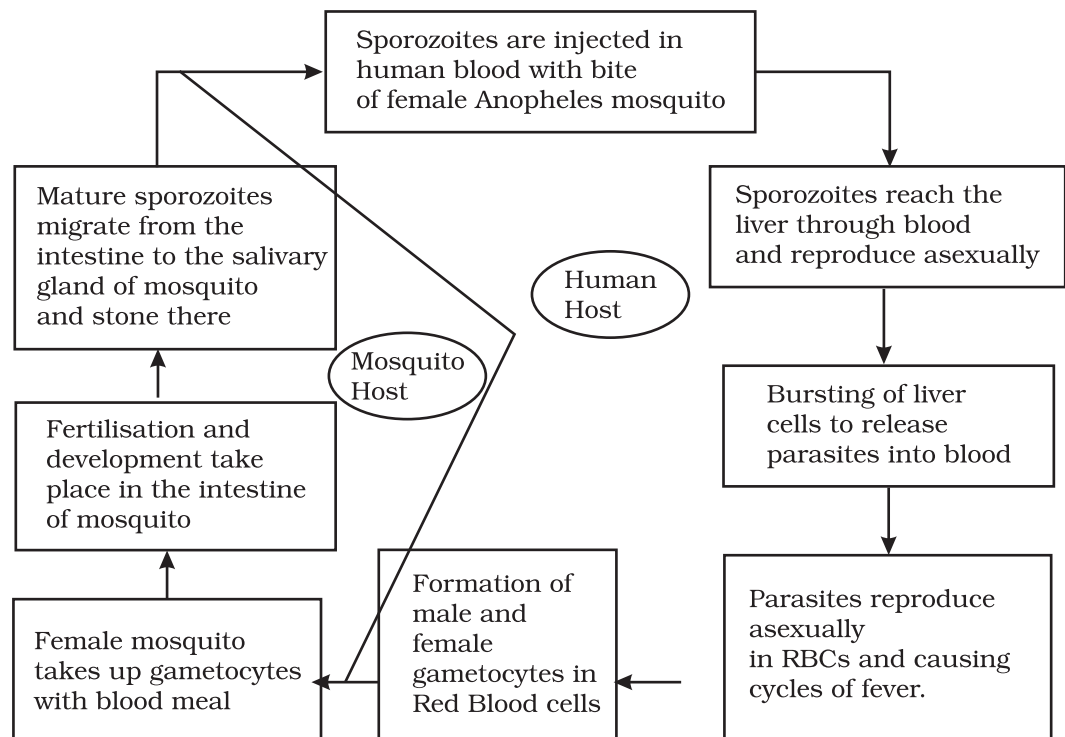

13. Why do some adolescents start taking drugs. How can the situation be avoided?

Ans. The reasons why adolescents and youngsters take to consumption of drugs are:

- (i) Curiosity of child motivates him/her to experiment.
- (ii) Need for adventure and excitement.
- (iii) Peer group pressure

- (iv) Desire to do more physical and mental work.
- (v) To overcome frustration and depression, due to failure in examinations or in other activities.
- (vi) Unstable or unsupportive family structures.

The following measures can be taken to avoid taking drugs:

- (i) Avoid undue pressure on child to perform beyond his/her capability in studies, sports or any other activities.
- (ii) Education and counselling are very important to face problem of stress and failure in life.
- (iii) Seeking help from parents, elders and peers. This would help the young to share their feelings and concern.
- (iv) Looking for danger signs and taking appropriate measures to treat them.
- (v) Seeking professional and medical help for de-addiction and rehabilitation.

14. (a) The shift from grain to meat diets creates more demands for cereals? Why?
- (b) A 250 Kg cow produces 200 g of protein per day but 250 g of *Methylophilus methylotrophus* can produce 25 tonnes of protein. Name this emerging area of research. Explain its benefits.

- Ans. (a) It takes 3–10 kg of grain to produce 1 kg of meat using animal farming. That is why cereals demand increases.
- (b) Production of single cell proteins (SCP) by microbes. Microbes are being grown on an Industrial scale. *Spirulina* can be easily grown on starch, molasses etc., and can make food which is rich in proteins, minerals, fats, carbohydrates and vitamins. This could be a good alternative for dealing with the problem of malnutrition.

15. Draw a diagrammatic sketch of biogas plant, and label its various components.

Ans. Diagram of Biogas Plant from the textbooks

16. Describe critically the main ideas behind the biological control of pests and diseases.

Ans. Biological control means life against life. It's a natural and ecofriendly concept. It employs the natural organisms to control the population of pathogens and pests in an ecosystem. Classical examples are *Trichoderma* which is antagonist against many soil borne plant pathogens. Similarly, *Penicillium* inhibits the growth of *Staphylococcus* and therefore has been successfully used in the production of Penicillin antibiotic to control many human bacterial pathogens.

17. For selection of recombinants, insertional inactivation of antibiotic marker has been superceded by insertional inactivation of a marker gene coding for a chromogenic substrate. Give reasons.

Ans: Selection of recombinants due to inactivation of antibiotics is a laborious process as it requires:

- (i) a vector with two antibiotic resistance marker
- (ii) preparation of two kinds of media plate, with one antibiotic each.

Transformed cells are first plated on that antibiotic plate which has not been insertionaly inactivated (ampicillin) and incubated overnight for growth of transformants. For selection of recombinants, these transformants are Replica plated on second antibiotic (tetracycline) plate (which got inactivated due to insertion of gene). Non-Recombinants grow on both the plates (one carrying ampicillin and the other carrying tetracycline) while recombinants will grow only on ampicillin plate.

This entire exercise is laborious and takes more time (two overnight incubation) as well. However, if we choose the second option (insertional inactivation of a marker that produces colour in the presence of a chromogenic compound), we can distinguish between the recombinants and non-recombinants on a single medium plate (containing one antibiotic and the chromogenic compound) after overnight growth.

Hence I would choose a marker which produces a coloured compound but gets inactivated due to insertion of foreign DNA.

18. Describe the role of *Agrobacterium tumefaciens* in transforming a plant cell.

Ans. *Agrobacterium tumefaciens* harbours a mega plasmid called Ti-plasmid. This has a T-DNA region flanked by left border and right border sequence. The T-DNA gets transferred and integrates with the host plant DNA. This property of Ti-plasmid has been exploited for cloning of gene of interest and stably integrating them in the plant genome. Therefore, by using Ti-plasmid or its derivatives, recombinant plant cells with desired genes of interest stably integrated in the plant genome has been successfully produced.

19. Define transgenic animals. Explain in detail any four areas where they can be utilised.

Ans. Transgenic animals are products of genetic engineering and express specific gene(s) from totally unrelated source. Following are the four main areas where they can be utilised.

- 1) To study normal physiology and development these animals can be used to study as to which factor / gene products are needed at what time of development. By expression of certain genes, they

help scientists to understand the normal gene expression at various stages of growth and development.

2) Study of Diseases

Transgenic animals can be created to serve as models for various human diseases. They also help us understand the involvement of various genes in diseases like cancer, Parkinson' disease etc.

3) Vaccine safety

Transgenic animals can be used to test vaccines like polio vaccine. Transgenic mice have shown promising results in this area and would replace the vaccine testing on monkeys in the years to come.

4) Chemical safety testing

Transgenic animals are created which are more sensitive to certain chemicals / drugs. These are used to study the toxicity or side effects of that chemical / drug. The advantage is that we get results faster.

3. You have identified a useful gene in a bacteria. Make a flow chart of the steps that you would follow to transfer this gene to a plant.

Ans. After identifying a useful gene in bacteria, following steps should be undertaken

- (1) Isolation of useful gene using Restriction Endonucleases
- ↓
- (2) Transferring the gene to a suitable vector to create a recombinant DNA molecule
- ↓
- (3) Transfer of these recombinant DNA molecules to the target cells
- ↓
- (4) Screening of cells for transformation
- ↓
- (5) Selection of transformed cells
- ↓
- (6) Regeneration of plants from the transformed cells to get transgenic plants.

20. List the disadvantages of insulin obtained from the pancreas of slaughtered cows and pigs:

Ans. (1) Insulin being a hormone is produced in very little amounts in the body. Hence, a large number of animals need to be sacrificed for

obtaining small quantities of insulin. This makes the cost of insulin very high. [Demand being many fold higher than supply].

- (2) Slaughtering of animals is also not ethical.
- (3) There is potential of immune response in humans against the administered insulin which is derived from animals.
- (4) There is possibility of slaughtered animals being infested with some infectious micro organism which may contaminate insulin.

21. What do you understand by the term bio-pesticide? Name and explain the mode of action of a popular bio-pesticide.

- Ans. Biopesticide is a pesticide which is
- a. not chemical in nature
 - b. more specific in action against the pest
 - c. safer for environment than chemical pesticides

A popularly known bio-pesticide is Bt toxin, which is produced by a bacterium called *Bacillus thuringiensis*. Bt toxin gene has been cloned from this bacterium and expressed in plants. Bt toxin protein when ingested by the insect, gets converted to its active form due to the alkaline pH of the gut. The activated toxin binds to the surface of midgut epithelial cells and create pores that cause cell swelling and lysis and eventually kills the insect.

22. Name the five key tools for accomplishing the tasks of recombinant DNA technology. Also mention the functions of each tool.

- Ans.
- i. Restriction endonucleases: for cutting the desired DNA at desired places
 - ii. Gel electrophoresis: for separating the desired DNA fragments
 - iii. Ligase enzyme: for creating recombinant DNA molecule.
 - iv. DNA delivery system: like electroporation, microinjection, gene gun method.
 - v. Competant host (usually bacteria / yeast): to take up recombinant DNA.

23. Comment on the following diagrams:

A, B, C, D, G, P, Q, R, S are species

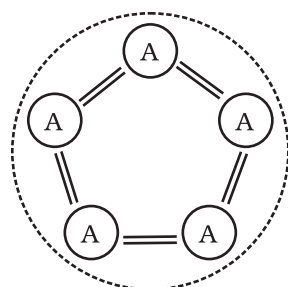

I

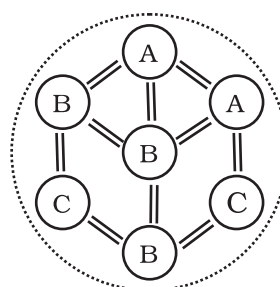

II

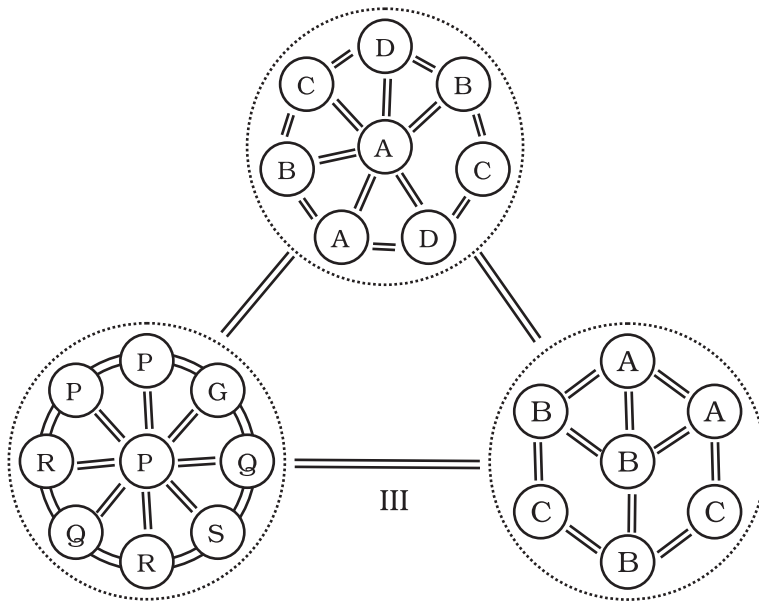

Ans.

- Fig.-I: It is a single population and all individuals are of the same species i.e. A. Individual interact among themselves and their environment.
- Fig.-II: It is a community and it contains three populations of species A,B and C. They interact with each other and their environment.
- Fig. III: It is a biome. It contains three communities. of which one is in climax and other two are in different stages of development. All three communities are in the same environment and they interact with each other and their environment.

24. The following diagrams are the age pyramids of different populations. Comment on the status of these populations.

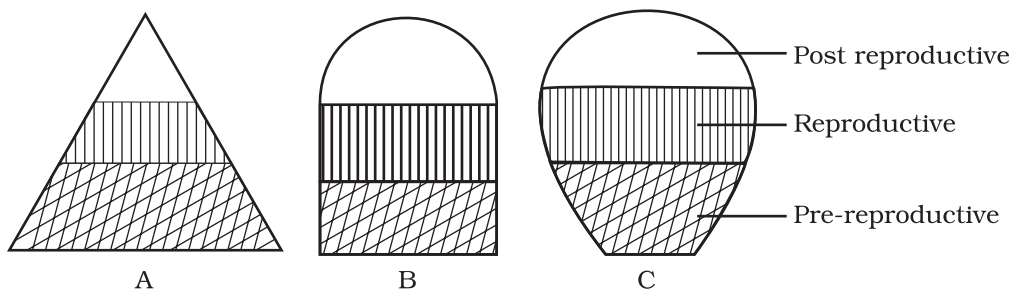

- Fig.A: It is a pyramid shaped age pyramid. In this figure, the base i.e pre-reproductive stage is very large when compared with the reproductive and past reproductive stages of the population. This type of age structure indicates that the population would increase rapidly.
- Fig.B: It is an inverted bell shaped pyramid. In this figure, the pre-reproductive and reproductive stages are same. This type of age structure indicates that the population is stable.

Fig.C: It is 'Urn' shaped pyramid. In this figure, the pre-reproductive and reproductive stages are less than the post reproductive stage of this population. In this population more older people are present. This type of age structure indicates that the population definitely is declining.

25. In an aquarium two herbivorous species of fish are living together and feeding on phytoplanktons. As per the Gausses principle, one of the species is to be eliminated in due course of time, but both are surviving. How? And what possibly happened to both the species?

Ans. Each species has a specific position or functional role within the community, called niche. According to the Gausses principle, no two species can live in the same niche. In this case, two herbivorous species are living in the same niche and feeding on phytoplanktons. It may be because of the availability of sufficient phytoplanktons/and or less number of individuals of the fish species. of the two species might have occurred. And though neither of the species have been eliminated, niche overlapping may effect the growth and development of individuals of the species.

26. What will happen to an ecosystem if

- a. All producers are removed;
- b. All organisms of herbivore level are eliminated; and
- c. All top carnivore population is removed

Ans. (a) Reduction in primary productivity. No biomass available for consumption by higher trophic levels / heterotrophs
 (b) Increase in primary productivity and biomass of producers.
 Carnivores population will subsequently dwindle due to food shortage.
 (c) Increase in number of herbivores
 Overgrazing by herbivores
 Desertification

27. Elaborate how invasion by an alien species reduces the species diversity of an area.

Ans. Some possible explanations are that the alien species may be

- i. Vigorously growing and compete with the natural plants for minerals, water etc. The less vigorous local species may be eliminated.
- ii. Natural pests and predators of the alien species may not be present in the introduced area-leading to proliferation in their number.
- iii. The introduced species may harm the local species by production of chemicals (Amensalism)
- iv. The alien species by proliferation may make conditions unfavourable for the growth of local native plants. (eg. *Eichornia*)

28. How can you, as an individual, prevent the loss of biodiversity?

Ans. The loss of biodiversity can be prevented by

- i. Practise of recycling waste paper etc.
- ii. Judicious exploitation of medicinal and commercial plants and animals.
- iii. Generating awareness among the public on the importance of biodiversity, conversation through skits, screening of films, lectures etc.

Teaching people how to reduce green house gases emissions, through alternate eco friendly green technologies like use of solar energy, wind energy, biogas, vermi compost, organic farming etc.

29. Write a short note on electronic waste. List the various sources of e- wastes and the problems associated with the disposal of e-waste.

Ans. Discarded unusable electronic gadgets such as computers, mobile phones, circuits, television sets, etc., form electronic waste. These contain harmful toxic substances like heavy metals to which the unskilled manual workers are directly exposed.

30. What are the basic characteristics of a modern land fill sites. List any three and mention the reasons for their use.

Ans. Characteristics of a modern land fill include

- i) Methods to contain leachate such as lining clay or plastic liners.
- iii) Compaction and covering of the waste to prevent it being blown by wind.
- iv) Installation of a land fill gas extraction system to extract the gas for use in generation of power.

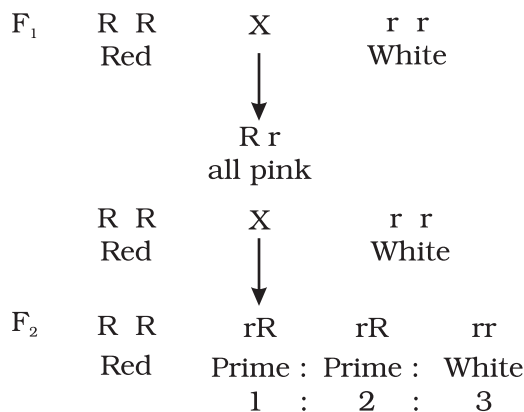

Phenotypic ratio:

Genotypic ratio:

Here the genotypic and phenotypic ratios are the same. So, we can conclude that when genotypic and phenotypic ratios are the same, the alleles show incomplete dominance.

18. What is Down's syndrome? Give its symptoms and cause. Why is it that the chances of having a child with Down's syndrome increases if the age of the mother exceeds forty years?

Ans. Down's syndrome is a human genetic disorder caused due to trisomy of chromosome no. 21. Such individuals are aneuploid and have 47 chromosomes. ($2n + 1$) The symptoms include mental retardation, growth abnormalities, constantly open mouth, dwarfness etc. The reason for the disorder is the non-disjunction (failure to separate) of homologous chromosome of pair 21 during meiotic division in the ovum. The chances of having a child with Down's syndrome increase with the age of the mother (+ 40) because ova are present in females. since their birth and therefore older cells are more prone to chromosomal non-disjunction because of various physico-chemical exposures during the mother's life-time.

19. What are the characteristic features of a true-breeding line?

Ans. A true-breeding line for a trait is one that, has undergone continuous self-pollination or brother-sister mating, showing a stability in the inheritance of the trait for several generations.

20. In peas, tallness is dominant over dwarfness, and red colour of flowers is dominant over the white colour. When a tall plant bearing red flowers was pollinated by a dwarf plant bearing white flowers, the different phenotypic groups were obtained in the progeny in numbers mentioned against them.

Tall, Red = 138

Tall, White = 132

Dwarf, Red = 136

Dwarf, White = 128

Mention the genotypes of the two parents and of the types of four offspring.

Ans. The result shows that the four types of offspring are in a ratio of 1:1:1:1. Such a result is observed in a test-cross progeny of a dihybrid cross.

The cross can be represented as:

Tall & Red (Tt Rr) × Dwarf & white (ttrr)

offsprings		tr		
Tt Rr – Tall, Red	TR	TtRr	Tall	Red
Tt rr – Tall, White	Tr	Ttrr	Tall	White
Tt Rr – dwarf, red	tR	ttRr	dwarf	Red
tt rr – dwarf, white.	tr	ttrr	dwarf	white

21. Why is the frequency of red-green colour blindness is many times higher in males than that in the females?

Ans. For becoming colourblind, the female must have the allele for it in both her X-chromosomes; but males develop colourblindness when their sole x-chromosome has the allele for it.

22. If a father and son are both defective in red-green colour vision, is it likely that the son inherited the trait from his father? Comment.

Ans. Gene for colourblindness is X-chromosome linked, and sons receive their sole from their mother, not from their father. Male-to-male inheritances is not possible for X-linked traits in humans. In the given case the mother of the child must be a carrier. (heterozygous) for colour blindness gene.

23. Retrovirus do not follow central dogma. Comment.

Ans. Genetic material of retrovirus is RNA. At the time of synthesis of protein, RNA is 'reverse transcribed' to its complementary DNA first, which is opposite to the central dogma. Hence, retrovirus are not known to follow central dogma.

24. In an experiment, DNA is treated with a compound which tends to place itself amongst the stacks of nitrogenous base pairs. As a result of which, the distance between two consecutive base increases. from 0.34nm to 0.44 nm. Calculate the length of DNA double helix (which has 2×10^9 bp) in the presence of saturating amount of this compound.

Ans. $2 \times 10^9 \times 0.44 \times 10^{-9}/\text{bp}$

25. What would happen if histones were to be mutated and made rich in amino acids aspartic acid and glutamic acid in place of basic amino acids such as lysine and arginine?

Ans. If histone proteins were rich in acidic amino acids instead of basic amino acids then they may not have any role in DNA packaging in eukaryotes as DNA is also negatively charged molecule. The packaging of DNA around the nucleosome would not happen. Consequently, the chromatin fibre would not be formed.

26. Recall the experiment done by Frederick Griffith. If RNA, instead of DNA was the genetic material, would the heat killed strain of *strepts* have transformed the R-strain into virulent strain? Explain your answer.

Ans. RNA is more labile and prone to degradation (owing to the presence of 2' OH group in its ribose). Hence heat-killed S-strain may not have retained its ability to transform the R-strain into virulent form if RNA was its genetic material.

27. You are repeating the Hershey-Chase experiment and are provided with two isotopes: ^{32}P and ^{15}N (in place of ^{35}S in the original experiment). How do you expect your results to be different?

Ans. Use of ^{15}N will be inappropriate because method of detection of ^{35}P and ^{15}N is different (^{32}P being a radioactive isotope while ^{15}N is not radioactive but is the heavier isotope of Nitrogen). Even if ^{15}N was radioactive then its presence would have been detected both inside the cell (^{15}N incorporated as nitrogenous base in DNA) as well as in the supernatant because ^{15}N would also get incorporated in amino group of amino acids in proteins). Hence the use of ^{15}N would not give any conclusive results.

28. There is only one possible sequence of amino acids when deduced from a given nucleotides. But multiple nucleotide sequences can be deduced from a single amino acid sequence. Explain this phenomena.

Ans. Some amino acids are coded by more than one codon (known as degeneracy of codons), hence on deducing a nucleotide sequence from an amino acid sequence, multiple nucleotide sequence will be obtained. For e.g., Ile has three codons: AUU, AUC, AUA hence a dipeptide Met-Ile can have the following nucleotide sequence:

- (i) AUG - AUU
- (ii) AUG - AUC
- (iii) AUG - AUA

and if, we deduce amino acid sequence for the above nucleotide sequences, all the three will code for Met-Ile

29. A single base mutation in a gene may not 'always' result in loss or gain of function. Do you think the statement is correct? Defend your answer.

Ans. The statement is correct. Because of degeneracy of codons, mutations at third base of codon, usually does not result into any change in phenotype. This is called silent mutations.

30. A low level of expression of lac operon occurs at all the time. Can you explain the logic behind this phenomena.

Ans. In the complete absence of expression of lac operon, permease will not be synthesised which is essential for transport of lactose from medium into the cells. And if lactose cannot be transported into the cell, then it cannot act as inducers hence, cannot relieve the lac operon from its repressed state.

31. Would it be appropriate to use DNA probes such as VNTR in DNA fingerprinting of a bacteriophage?

Ans. Bacteriophage does not have repetitive sequences such as VNTRs in its genome as its genome is very small and have all the coding sequence. DNA finger printing is not done for phages.

32. During in vitro synthesis of DNA, a researcher used 2', 3' - dideoxy cytidine triphosphate as raw nucleotide in place of 2'-deoxy cytidine triphosphate other conditions remaining as standard. Will further polymerisation of DNA continue upto the end or not? Explain.

Ans. Further polymerisation would not occur, as the 3' OH on sugar is not there to add a new nucleotide for forming ester bond.

33. What background information did Watson and Crick had available with them for developing a model of DNA? What was their own contribution?

Ans. Wastson and Crick had the following informations which helped them to develop a model of DNA.

- (i) Chargaffs' Law suggesting $A = T$, and $C = G$.
- (ii) Wilkins and Rosalind Franklin's work on DNA crystal's X-ray diffraction studies about DNA's physical structure.
- (iii) Watson and crick proposed
 - a. How complementary bases may pair
 - b. Semi conservative replication and
 - c. Mutation through tautomerism.

34. What are the functions of (i) methylated guanasine cap, (ii) poly-A "tail" in a mature on RNA?

Ans. Methylated Guanine cap helps in binding of mRNA to smaller ribosomal sub-unit during initiation of translation. Poly- A tail provides longevity to mRNA's life. Tail length and longevity of mRNA are positively correlated.

35. Do you think that the alternate splicing of exons may enable a structural gene to code for several isoproteins from one and the same gene? If yes, how? If not, why so?

Ans. Functional mRNA of structural genes need not always include all of its exons. This alternate splicing of exons is sex-specific, tissue-specific, and even developmental stage-specific. By such alternate splicing of exons, a single gene may encode for several isoproteins and/or proteins of similar class. In absence of such a kind of splicing, there should have been new genes for every protein/isoprotein. Such an extravagancy has been avoided in natural phenomena by way of altemate splicing.

36. Comment on the utility of variability in number of tandem repeats during DNA finger printing.

Ans. Tandemness in repeats provides many copies of the sequence for finger-printing, and variability in nitrogen base sequence in them. Being individual-specific, this proves to be useful in the process of DNA fingerprinting.

37. Scientists claim that nascent oxygen is toxic to aerobic life forms. What are the reasons.

Ans. Nascent oxygen is highly reactive. It can react readily with different kinds of molecules, including DNA, proteins present in the cells of aerobic life forms. This may lead to mutations and undesirable metabolic changes.

38. While creation and presence of variation is directionless, natural selection is directional as it is in the context of adaptation. Comment.

Ans. Creation and variation occur in a sexually reproducing population as a result of crossing over during meiosis and random fusion of gametes. It is however the organisms that are selected over a period of time which are determined by the environmental conditions. In other words, the environment provides the direction with respect to adaptations so that the organisms are more and more fit in terms of survival.

39. Gene flow occurs through generations, and can occur across language barriers in humans. If we have a technique of measuring specific allele frequencies in different population of the world, can we not predict human migratory patterns in pre-history and history? Do you agree or disagree? Provide explanation to your answer.

Ans. Yes, I agree. Gene flow occurs through generations. By studying specific allele frequencies, we can predict the human migratory patterns in pre-history and history. Studies have used specific genes/chromosomes/mitochondrial DNA to trace the evolutionary history and migratory patterns of humans. (The project is known as the Human Genographics Project).

40. When we say "survival of the fittest", does it mean that

- a. Those which are fit only survive, or
- b. Those that survive are called fit

Comment.

Ans. Those individuals which survive and reproduce in their respective environment are called fit.

41. Enumerate three most characteristic criteria for designating a Mendelian population.

Ans. Population must be sufficiently large with potentialities for free flow of genetic material among individuals (through sexual reproduction). Migration should either be nil or negligible.

42. "Migration may enhance or blur the effects of selection". Comment.

Ans. Migration may cause enrichment of the gene pool of such alleles that are being selected for or null the effects of selection through replenishment of alleles that were selected against by nature.

43. From which plant are Cannabinoids obtained? Name any two Cannabinoids. Which part of the body is effected by consuming these substances?

Ans. Cannabinoids are obtained from the inflorescence of the plant *Cannabis sativa*. Marijuana, hashish, charas, ganja are some Cannabinoids.

These chemicals interact with Cannabinoid receptors of the body, mainly present in the brain. Cardiovascular system is effected adversely.

44. In the metropolitan cities of India, many children are suffering from allergy/asthma. What are the main causes of this problem. Give some symptoms of allergic reactions.

Ans. Allergy is the exaggerated response of the immune system of certain antigens present in the environment. In metropolitan cities life style is responsible in lowering of immunity and sensitivity to allergens. More polluted environment increases the chances of allergy in children. Some symptoms of allergic reactions are sneezing, watery eyes, running nose and difficulty in breathing.

45. What is the basic principle of vaccination? How do vaccines prevent microbial infections? Name the organism from which hepatitis B vaccine is produced.

Ans. The principle of vaccination is based on the property of 'memory' of the immune system. In vaccination, a preparation of antigenic proteins of pathogens or inactivated/live but weakened pathogens is introduced into the body. The antigens generate the primary immune response by producing antibodies. The vaccines also generate the memory B-cells and T-cells. When the vaccinated person is attacked by the same pathogens, the existing memory B-cells or T-cells recognises the antigen quickly and overwhelm the invaders with massive production of lymphocytes and antibodies. Hepatitis B vaccine is produced from yeast.

46. What is Cancer? How is a Cancer cell different from normal cell? How do normal cells attain Cancerous nature?

Ans. An abnormal and uncontrolled division of cells is termed as Cancer.

The Cancerous cells are different from the normal cells in the following ways.

Cancer Cells	Normal Cells
1. Cancer cells divide in an uncontrolled manner.	1. Normal cells divide in a controlled manner.
2. The cells do not show contact inhibition	2. The cells show contact inhibition.
3. Life span is indefinite	3. Life span is definite.

In our body, the growth and differentiation of cells is highly controlled and regulated. The normal cells show a property called contact inhibition. The surrounding cells inhibits uncontrolled growth and division of cells. The normal cells lose this property and become cancerous cells giving rise to masses of cells called tumors. Transformation of normal cells into cancerous cells is induced by some physical, chemical and biological agents (carcinogens).

47. A person shows strong unusual hypersensitive reactions when exposed to certain substances present in the air. Identify the condition. Name the cells responsible for such reactions. What precaution should be taken to avoid such reactions.

Ans. Allergy. Mast Cells are responsible for such reactions.

To avoid such reactions following precautions must be taken.

- (i) The use of drugs like antihistamine, adrenalin and steroids quickly reduce the symptoms of allergy.
 - (ii) Avoid contact with substances to which a person is hypersensitive.
48. Life style diseases are increasing alarmingly in India. We are also dealing with large scale malnutrition in the population. Is there any method by which we can address both these problems?

Ans. The answer to address both these problems is called biofortification. This area looks at improving food quality with respect to protein, oil, vitamin, micro nutrient and mineral content. The oils need to be rich in omega 3 fatty acids which are good for heart. Similarly, proteins should have more of lysine and tryptophan (essential amino acids). Many varieties of maize, carrots and spinach have been released which fulfil the above criteria.

49. How can we improve the success rate of fertilisation during artificial insemination in animal husbandry programmes?

Ans. The technology is called MOET or Multiple Ovulation Embryo Transfer. During the procedure, a cow is given hormonal treatment so that more than one ovule (6-8 eggs) is produced per cycle. After mating or artificial insemination the embryos at 8-32 celled state are transferred to different surrogate mother cows. The method has been successfully used for cattle, sheep, buffalo etc.

50. What is meant by germplasm collection? What are its benefits?

Ans. The collection of all the diverse alleles of all the genes of a crop plant is called germplasm collection. It is of great benefits in plant breeding programmes as it offers, to the breeders, the entire of genes and alleles and the characteristics which they express. The breeder selects the most favourable characters of a particular gene and manipulates its transfer to a desirable parent.

51. Name the three improved characteristics of wheat that helped India achieve green revolution.

Ans.

- i. Semi-dwarf nature
- ii. Quick yielding feature
- iii. High yielding feature
- iv. Disease resistant feature

52. Suggest two features of plants that will prevent insect and pest infestation

- Ans.
- i. increasing hair growth on aerial parts of plants.
 - ii. Rendering the flowers nectar less.
 - iii. Enabling plants to secrete insect killing chemicals (toxins)

53. What are the physical barriers of a cell in the protoplast fusion experiment? How are the barriers overcome?

Ans. Cell wall is the most important physical barrier in such experiments. This can be overcome by treatment with enzymes like cellulase and pectinase which have the ability to digest the cell wall and liberate the naked protoplast surrounded only by the cell membrane.

54. Give two examples of biofortified crops. What benefits do they offer to the society?

Ans. Maize, wheat, rice, bathua, spinach, pulses have biofortified varieties. Maize hybrids have twice the amount of amino acids, fortified wheat variety has high protein content, fortified rice has high quantity of iron. Consumption of such biofortified foods will enrich the nutritive value of our common foods and will vastly improve public health. Instead of consuming different food items for obtaining different nutrients, if 2 or 3 nutrients can be incorporated into a single crop, it offers enormous benefits to human beings and may even help cover some several nutrient deficiency disorders latent in our country.

55. How has the bacterium *Bacillus thuringiensis* helped us in controlling caterpillars of insect pests?

Ans. *Bacillus thuringiensis* produces endotoxin which when ingested and released in the gut of the larvae of insect pest disrupts the insect gut lining thereby killing them.

56. How do mycorrhizal fungi help the plants harbouring them?

Ans. The mycorrhizal fungi absorb phosphorus from the soil and transfer them to the host cells. They also impart resistance to host plants against root pathogens. They also help plants tolerate salinity and drought.

57. How was penicillin discovered?

Ans. Penicillin was an accidental discovery. Sir Alexander Fleming observed that in unwashed culture plates of *Staphylococcus*, a mould *Penicillium* was growing. This mould inhibited the growth of *Staphylococcus*. Later the antibiotic *Penicillin* was isolated from this fungus.

58. What is the chemical nature of biogas. Name an organism which is known to be employed in biogas?

Ans. The chemical nature of Biogas is methane, CO_2 & H_2 . *Methanobacteria*, a type of methanogen is employed for biogas production.

59. What is a broad spectrum antibiotic? Name a broad spectrum antibiotic and source organism.

Ans. A broad spectrum antibiotic is one which can inhibit the growth of both G +ve & G -ve bacteria.

60. What do you understand by gene cloning?

Ans. Gene cloning refers to a process in which a gene of interest is ligated to a vector. The recombinant DNA thus produced is introduced in a host cell by transformation. Each cell gets one DNA molecule and when the transformed cell grows to a bacterial colony, each cell in the colony has a copy of the gene. This is precisely gene cloning.

61. A wine maker and a molecular biologist who has developed a recombinant vaccine, both claim themselves to be biotechnologist. Who in your opinion is right?

Ans. Both. As biotechnology is a very wide area which deals with techniques of using a 'natural' organism (or its parts) as well as genetically modified organism to produce products and processes useful for mankind. A wine maker employs a strain of yeast to produce wine by fermentation (a natural phenomenon), while the molecular biologist has cloned gene for the antigen (that is used as vaccine) in an organism which allows the production of the antigen in large amount.

62. You have created a recombinant DNA molecule by ligating a gene to a plasmid vector. By mistake, your friend adds exonuclease enzyme to the tube containing the recombinant DNA. How will your experiment get affected as you plan to go for transformation now?

Ans. The experiment will not likely to be affected as recombinant DNA molecule is circular closed, with no free ends. Hence, it will not be a substrate for exonuclease enzyme which removes nucleotides from the free ends of DNA.

63. The restriction enzymes that are used in construction of recombinant DNA molecule are endonucleases which cut the DNA at 'specific-recognition sequence'. What would be the disadvantage if they would not cut the DNA at specific-recognition sequence?

Ans. If the restriction enzymes would cut DNA at random sites instead of at specific sites, then the DNA fragments obtained will not have 'sticky ends'. In the absence of sticky ends, construction of recombinant DNA molecule would not be possible.

64. A plasmid DNA and a linear DNA (both of the same size) have one site for a restriction endonuclease. When cut and separated on agarose gel electrophoresis, plasmid shows one DNA band while linear DNA shows two fragments. Explain.

Ans. It is because plasmid is a circular DNA molecule. When cut with enzyme, it becomes linear but does not get fragmented. Whereas, a linear DNA

molecule gets cut into two fragment. Hence, a single DNA band is observed for plasmid while two DNA bands are observed for linear DNA in agarose gel.

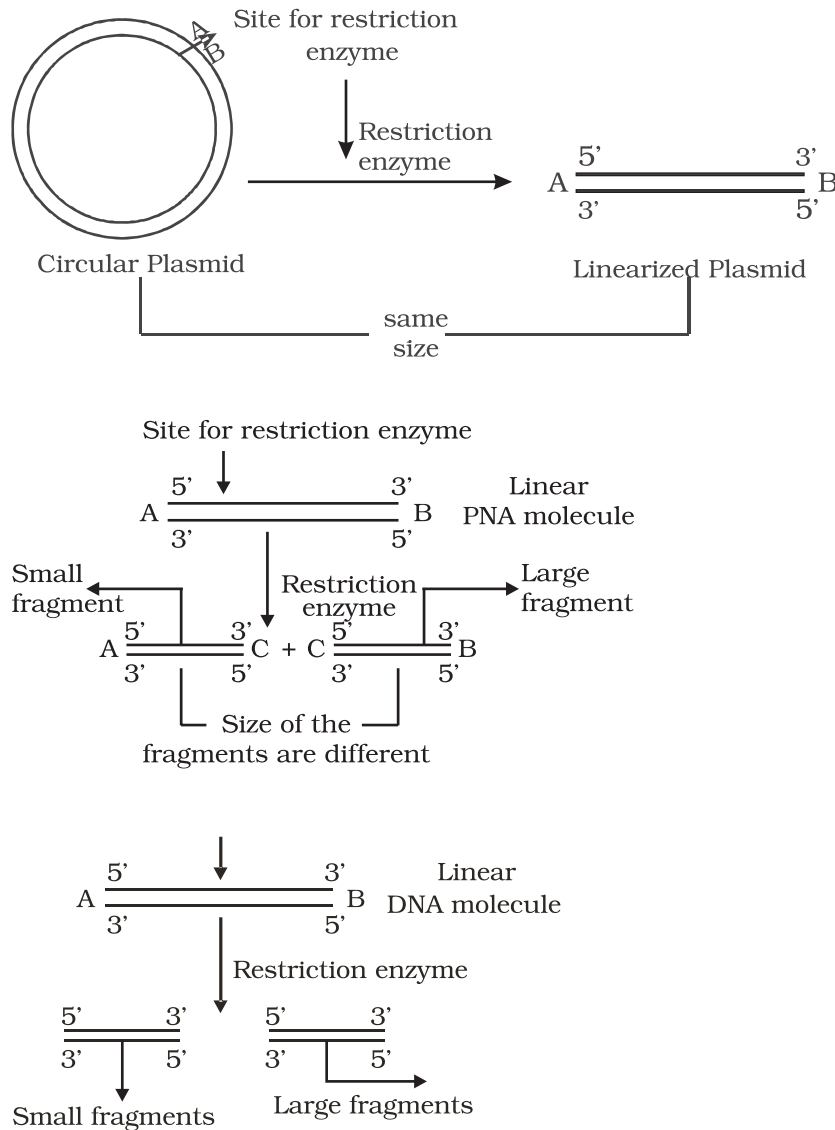

65. How do you visualise DNA on an agarose gel?

Ans. A compound called Ethidium Bromide stains DNA, which on irradiating with Ultra Violet, fluoresce and gives orange light. Hence, DNA fragments appear as orange band in the presence of Ethidium Bromide and UV.

66. You have chosen a plasmid as vector for cloning your gene. However this vector plasmid lacks a selectable marker. How would it affect your experiment?

Ans. In a gene cloning experiment, first a recombinant DNA molecule is constructed, where the gene of interest is ligated to the vector, [The step would not be affected] and introduced inside the host cell (transformation). Since, not all the cells get transformed with the recombinant / plasmid DNA, in the absence of selectable marker, it will be difficult to distinguish between transformants and non-transformant, because role of selectable marker is in the selection of transformants.

67. A mixture of fragmented DNA was electrophoresed in agarose gel. After staining the gel with ethidium bromide, no DNA bands were observed. What could be the reason?

The reasons are as follows:

- Ans. (i) DNA sample that was loaded on the gel may have got contaminated with nuclease (exo-or endo-or both) and completely degraded.
- (ii) Electrodes were put in opposite orientation in the gel assembly that is anode towards the wells (where DNA sample is loaded). Since DNA molecules are negatively charged, they move towards anode and hence move out of the gel instead of moving into the matrix of gel.
- (iii) Ethidium bromide was not added at all or was not added in sufficient concentration and DNA was not visible.

68. Describe the role of CaCl_2 in preparation of competent cells?

Ans. CaCl_2 is known to increase the efficiency of DNA uptake to produce transformed bacterial cells. The divalent Ca^{+2} ions supposedly create transient pores on the bacterial cell wall by which the entry of foreign DNA is facilitated into the bacterial cells.

69. What would happen when you grow a recombinant in a bioreactor but forget to add antibiotic to the medium in which the recombinant is growing.

Ans. In the absence of antibiotic, there will be no pressure on recombinants to retain the plasmid (containing the gene of your interest). Since, maintaining a high copy number of plasmids is a metabolic burden to the microbial cells, will thus tend to lose the plasmid.

70. Gene expression can be controlled with the help of RNA molecule. Explain the method with an example.

Ans. Gene expression can be controlled by using RNA molecule. The technology is called RNA interference or RNAi. It is used to block the expression of certain genes and also referred to as gene silencing. During this process a complementary RNA to the mRNA being produced by the gene is introduced into the cell. This RNA binds to the mRNA making it double stranded and therefore stops translation. Resistance to nematode *Meloidogyne incognita* in tomato has been achieved by this method.

71. Define the terms Antigen and Antibody. Name any two diagnostic kits based upon them.

Ans. An antigen is a foreign substance that elicits the formation of an antibody. Antibody is a protein that is synthesised in response to an antigen. Antigen and antibody show high degree of specificity in binding each other. Two diagnostic kits based on an antigen-antibody interaction are.

- a. ELISA for HIV.
- b. Pregnancy test kits.

72. ELISA technique is based on the principles of antigen and antibody interaction. Can this technique be used in the molecular diagnosis of a genetic disorder, such as phenylketonuria?

Ans. Yes. One can use antibody against the enzyme (that is responsible for the metabolism of phenylalanine) to develop ELISA based diagnostic technique. The patient where the enzyme protein is absent would give negative result in ELISA when compared to normal individual.

73. How is a mature, functional insulin hormone different from its pro-hormone form?

Ans. Mature functional insulin is obtained by processing of pro-hormone which contains extra peptide called C-peptide. This C-peptide is removed during maturation of pro-insulin to insulin.

74. Gene therapy is an attempt to correct a genetic defect by providing a normal gene into the individual. By this the normal function can be restored. Alternate method would be to provide the gene product (protein/enzyme) known as enzyme replacement therapy, which would also restore the function. Which in your opinion is a better option? Give reason for your answer.

Ans. Gene therapy would be a better option because it has the potential to completely cure the patient. It is because the correct gene once introduced in the patient, can continue to produce the correct protein / enzyme. Enzyme therapy does not offer permanent cure as it needs to be given to the patient on regular basis. It is also more expensive therapy.

75. Transgenic animals are the animals in which a foreign gene is expressed. Such animals can be used to study the fundamental biological process/phenomenon as well as for producing products useful for mankind. Give one example for each type.

Ans. Study basic biological process- how genes are regulated, how they affect the normal functions of the body and its development. Transgenic cow, Rosie is the example for the second category.

76. When a foreign DNA is introduced into an organism, how is it maintained in the host and how is it transferred to the progeny of the organism?

- Ans. Foreign gene is usually ligated to a plasmid vector and introduced in the host. As plasmid replicates, and makes multiple copies of itself, so does the foreign gene gets replicated and its copies are made. When the host organism divides, its progeny also receives the plasmid DNA containing the foreign gene.
77. Bt cotton is resistant to pest, such as lepidopteron, dipterans and coleopterans. Is Bt cotton resistant to other pests as well?
- Ans. Bt cotton is made resistant to only certain specific taxa of pests. It is quite likely that in future, some other pests may infest this Bt cotton plants. It is similar immunisation against small-pox which does not provide immunity against other pathogens like those that causes cholera, typhoid etc.
78. Why are coral reefs not found from West Bengal to Andhra Pradesh but found in Tamil Nadu on the east coast of India?
- Ans. High salinity, optimal temperature and less siltation are essential to colonise corals. If siltation and fresh water inflow are very high, the corals don't colonise. In contrast when the siltation and fresh water inflow by the rivers are very less, the coral do colonise.
79. In a sea shore, the benthic animals live in sandy, muddy and rocky substrata and accordingly developed the following adaptations. Find the suitable substratum against each adaptation.
- Burrowing _____
 - Building cubes _____
 - Holdfasts / peduncle _____
- Ans. a. Sandy, b. Muddy, c. Rocky
80. Plants living in the water are called hydrophytes, Those living in the areas with water scarcity are called xerophytes; and the plants living in saline waters are called halophytes. Write the type of plant against the following examples.
- Salvinia* _____
 - Opuntia* _____
 - Rhizophora* _____
 - Mangifera* _____
- Ans. a. Hydrophyte, b. Xerophyte, c. Halophyte, d. Mesophyte
81. In a pond, we see plants which are free-floating; rooted-submerged; rooted emergent; rooted with floating leaves; Write the type of plant against the following examples.
- Hydrilla* _____
 - Typha* _____

- c. *Nymphaea* _____
 d. *Lemna* _____
 e. *Vallisnaria* _____

Ans. a. submerged, b. Rooted emergent, c. Rooted with floating leaves, d. free – floating, e. Rooted Submerged

82. Number of individuals of a population in a habitat per unit area is called density and density is measured in different units. Write the unit of measurement against the following:

- a. Bacteria
 b. Grass
 c. Banyan
 d. Deer
 e. Fish

Ans. a. Nos. / Vol; b. Coverage / area; c. Biomass / area; d. Nos. / area; e. Wt. / area

83. What is a tree line?

Ans: When we go up the altitude, beyond a particular height no trees are found and the vegetation comprises only of shrubs and herbs. The altitude beyond which no tree is seen is known as tree line.

84. Is it Possible to achieve 'zero population growth rate? If yes, what kind of age pyramid is obtained?

Ans. Yes. An inverted bell shaped age pyramid is obtained. The young of pre reproductive age group individuals are less in number and both pre- reproductive and reproductive stages are in the same level.

85. The number of trophic levels in an ecosystem are limited. Comment.

Ans. In a food chain, only 10% of the total amount of energy is passed on to the next trophic level from the previous trophic level. So, there is a decrease in the amount of energy available at the successive trophic levels. As we move higher up in the food chain the amount of energy diminishes to a level at which it cannot sustain any trophic level, thereby limiting the number of trophic levels.

86. What could be the reason for the fast rate of decomposition in the tropics?

Ans. The rate of decomposition is regulated by climatic factors like temperature and soil moisture as they have an effect on the activities of soil microbes. The tropics with its hot and humid climatic condition provides an environment which is ideal for the microbes to speed up the process of decomposition.

87. Flow of energy through various trophic levels in an ecosystem is unidirectional and non cyclic. Explain.

Ans. The energy from the sun reaches the food chain through the primary producers (plants). This energy is passed on through successive trophic levels in the food chain. The energy transfer in the food chain follows the 10 percent law where in only 10% of the energy is transferred from one trophic level to the next successively. So, the movement of energy is only in one direction from lower to higher trophic level.

88. Apart from plants and animals, microbes form a permanent biotic component in an ecosystem. While plants have been referred to as autotrophs and animals as heterotrophs, what are microbes referred to as? How do these microbes fulfil their energy requirements?

Ans. Microbes are referred to as heterotrophs and saprotrophs. They fulfil their energy requirement by feeding on dead remains of plants and animals through the process of decomposition.

89. Primary productivity varies from ecosystem to ecosystem. Explain?

Ans. Primary productivity varies from ecosystem to ecosystem because it depends on the plant species inhabiting the area and their photosynthetic activity. It also depends on various environmental factors.

90. Sometimes due to biotic/abiotic factor the community remains in a particular seral stage (Pre climax) without reaching the climax. Do you agree with this statement. If yes give a suitable example.

Ans. It is true that any change in the abiotic/biotic factor will arrest a particular seral stage leading to a pre climax condition before the climax stage is achieved. This can happen in cases of forest fires, landslides, changes in soil characteristics, increase in herbivore population leading to overgrazing.

91. What is an incomplete ecosystem? Explain with the help of a suitable example.

Ans. An ecosystem is a functional unit with biotic and abiotic factors interacting with one another resulting in a physical structure. Absence of any component will make an ecosystem incomplete as it will hinder the functioning of the ecosystem. Exemplar of such an ecosystem can be a fish tank or deep aphotic zone of the oceans where producers are absent.

92. What are the shortcomings of ecological pyramids in the study of ecosystem?

Ans. The ecological pyramid assumes a simple food chain and does not accommodate food webs. Thereby, it does not take into account the fact that species may belong to two or more trophic levels at a time. Also

saprophytes despite their vital role in ecosystem are given no place in the ecological pyramids.

93. The rate of decomposition of detritus is affected by the abiotic factors like availability of oxygen, pH of the soil substratum, temperature etc. Discuss.

Ans. The decomposition of detritus is due to activities of micro organisms. The rate of growth of microbes is affected by temperature. The pH of substratum affects the composition of microbes (acidophiles / basophiles) which degrade the dead organic matter. If oxygen is present, aerobic degradation occurs. In the absence of oxygen anaerobiosis sets in and there will be incomplete degradation. Also, the degradation is due to activity of exo enzymes secreted by the microbes and the activity of enzyme is affected by factors such as temperature etc.

94. How is the presently occurring species extinction different from the earlier mass extinctions?

Ans. Species extinction occurring at present is due to anthropogenic causes whereas the earlier extinction was due to natural causes.

95. Discuss one example, based on your day-to-day observations, showing how loss of one species may lead to extinction of another.

Ans. In case a species (x) becomes extinct, the plant and animal species (M, N, O, Z) associated within an obligatory way also become extinct. For example.

- (i) When a fish species which is a host for a number of parasites becomes extinct the parasite species which are uniquely dependent on the host fish will also become extinct.
- (ii) The insects may be polyphagous (feed on more than one plant species) or monophagous (feed on only one particular plant species) in nature. The monophagous insect species are valuable and may become extinct if the plant species upon which it feeds becomes extinct.

96. Why are conventional methods not suitable for the assessment of biodiversity of bacteria?

Ans. Many bacteria are not culturable under normal conditions in the laboratory. This becomes a problem in studying their morphological, biochemical and other characterisations which are useful for their assessment.

97. How do scientists extrapolate the total number of species on Earth?

Ans. Scientists make a statistical comparison of the temperate-tropical species richness of an exhaustively studied group of insects and extrapolate this ratio to other groups of animals and plants to come up with a gross estimate of the total number of species on earth.

98. Is it true that there is more solar energy available in the tropics? Explain briefly.

Ans. As one moves from the equator to the polar regions, the length of the day decreases and the length of the night increases. The length of day and night are the same at the equator.

99. What is hybrid vehicle technology. Explain the advantages with a suitable example?

Ans. Vehicles running on dual mode like petrol and CNG are hybrid vehicle. As CNG is a green fuel there is conservation of fossil fuels and reduction in the environmental pollution.

100. Is it true that if the dissolved oxygen level drops to zero the water will become septic. Give an example which could lower the dissolved oxygen content of an aquatic body.

Ans. Yes, the water become septic if the dissolved oxygen drops to zero. Organic pollution (biodegradable) is an example.

101. Name any one of the green house gases and its possible source of production on a large scale. What are the harmful effects of it?

Ans. CO₂ and Methane. CO₂ levels are increasing due to burning of fossil fuels, leading to Global Warming.

102. It is a common practice to plant trees and shrubs near the boundary walls of buildings. What purpose do they serve.

Ans. The plants growing near the boundary wall act as barriers for sound pollution and act as dust catchers.

ANSWERS TO LA TYPE QUESTIONS

1. Do all the gametes formed from a parent organism have the same genetic composition? Are the DNA in them identical copies of the parental genome? Analyse the situation with the background of gametogenesis and provide suitable explanation.

Ans. The gametes of a parent do not have the same genetic composition because they do not have identical copies of DNA. In the pachytene and diplotene stages of meiosis I, the phenomenon of crossing over and chiasma formation take place between homologous chromosomes. This shifts segments of DNA from one chromatid to another (homologous chromosomes) in a random manner resulting in several new combinations of DNA sequences. As a result, when meiotic division is completed, gametes possess DNA with varying degree of variations.

2. Although sexual reproduction is a long drawn, energy-intensive complex form of reproduction, many groups of organisms in Kingdom Animalia and Plantae prefer this mode of reproduction. Give atleast three reasons for this.

- Ans.
- Sexual reproduction brings about variation in the offspring.
 - Since gamete formation is preceded by meiosis, genetic recombination occurring during crossing over (meiosis-I), leads to a great deal of variation in the DNA of gametes.
 - The organism has better chances survival in a changing environment.

3. Rose plants produce large, attractive bisexual flowers but they seldom produce fruits. On the other hand Lady's finger produces plenty of fruits. Analyse the reasons for failure of fruit formation in rose.

Ans. Failure of fruit formation in rose may be due to several reasons. Some of the likely reasons are:

- Rose plants may not produce viable pollen.
 - Rose plants may not have functional egg.
 - Rose plants may have abortive ovules.
 - Being hybrids, the meiotic process may be abnormal resulting in non-viable gametes.
 - There may be self-incompatibility.
 - There may be internal barriers for pollen tube growth and/or fertilisation.
4. Starting with the zygote, draw the diagrams of the different stages of embryo development in a dicot.

Ans.

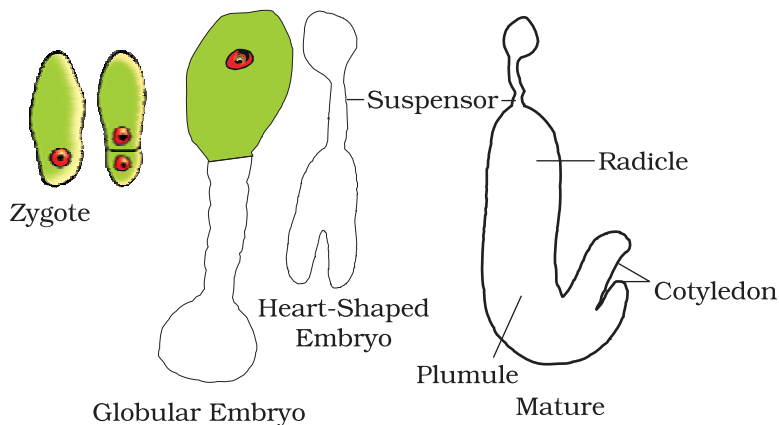

5. Embryo sacs of some apomictic species appear normal but contain diploid cells. Suggest a suitable explanation for the condition.

Ans. It is true that many apomicts possess normal looking embryo sacs. The only possibility of the embryo sac possessing diploid cells is due to failure of meiotic division at the megaspore mother cell stage. Since, the megaspore mother cell has a diploid nucleus, if it undergoes mitosis instead of meiosis, all the resulting nuclei and cells will be diploid in nature.

6. What role do pituitary gonadotrophins play during follicular and ovulatory phases of menstrual cycle and also explain the shift in steroidal secretions.

Ans. Menstrual cycle is regulated by hypothalamus through the pituitary gland. At the end of menstrual phase, the pituitary FSH gradually increases resulting in follicular development within the ovaries. As the follicles mature, Estrogen secretion increases resulting in a surge in (FSH and LH). The surge of LH is responsible for ovulation. LH also gonadotropins induces luteinisation. This leading to the formation of corpus luteum. Corpus luteum secretes progesterone and some estrogen which help in maintaining the uterine endometrium for implantation.

7. Meiotic division during oogenesis is different from that in spermatogenesis. Explain how and why?

Ans. Unequal cytoplasmic division of the oocyte is to ensure the retention of bulk of cytoplasm in one cell, instead of sharing it with two. It has to provide nourishment for the developing embryo during early stages, so it is essential to retain as much cytoplasmic material as it could in a single daughter cell.

8. Enumerate and describe any five reasons for introducing sex-education to school-going children.

Ans. Proper information about reproductive organs-physiology and its functioning; discourage myths and misconceptions about sex-related aspects; knowledge about safe and hygienic sexual practices; adolescence and related changes, prevention of STDs, AIDs etc.

9. a. In humans, males are heterogametic and females are homogametic, Explain. Are there any examples where males are homogametic and females are heterogametic?
b. Also describe as to, who determines the sex of an unborn child? Mention whether temperature has a role in sex determination.

Ans. (a) The term homogametic and heterogametic refer to the organism depending upon whether all the gametes contain one type of sex chromosome (Homo = same) or two different types of sex chromosomes (Hetero = different) Humans show XX/XY type of sex determination i.e. Females contain 2 copies of X chromosome and males contain 1 X & 1 Y chromosome. Therefore, ova produced by females contain the same sex chromosome i.e. X. On the other hand

the sperms contain 2 different types of chromosomes i.e. 50% sperms have X and 50% have Y chromosome open from half the autosomes (Meiosis) Therefore, the sperms are different with respect to the composition of sex chromosome. In case of humans, females are considered to be homogametic while males are heterogametic. Yes, there are examples where males are homogametic and females are heterogametic. In some birds the mode of sex determination is denoted by ZZ (males) and ZW (females).

- (b) As a rule the heterogametic organism determines the sex of the unborn child. In case of humans, since males are heterogametic it is the father and not the mother who decides the sex of the child. In some animals like crocodiles, lower temperature favour hatching of female offsprings and higher temperatures lead to hatching of male offsprings.

10. A normal visioned woman, whose father is colour blind, marries a normal visioned man. What would be the probability of her (a) sons (b) daughters to the colour blind? Explain with the help of pedigree chart.

Ans.

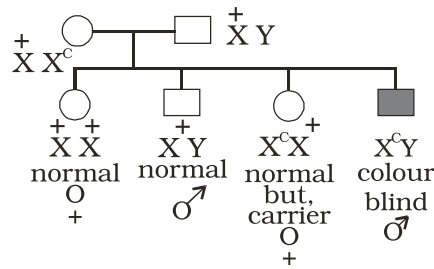

All daughters normal visioned; 50% of sons are likely to be colour blind.

11. You have studied the story of pepper moths in England. Had the industries been removed, what impact could it have had on the moth population? Discuss.

Ans. In the population of Peppermoth, 2 variants were already existing in the population, the black and the grey. In the absence of Industrialisation the grey moths were prevalent because they blended very well with the lichen and moss covered trees camouflage and the predators cannot spot them. The Black ones were easily spotted and killed by predators and therefore, were fewer in numbers. With Industrilisation the stems got covered with black soot. This provided better camouflage to the black variant and their number increased. If the industries had been removed the population of black moths would have declined because as stated earlier they would have been spotted better by predators and therefore be eaten more frequently.

12. Represent schematically the life cycle of malarial parasite.

Ans.

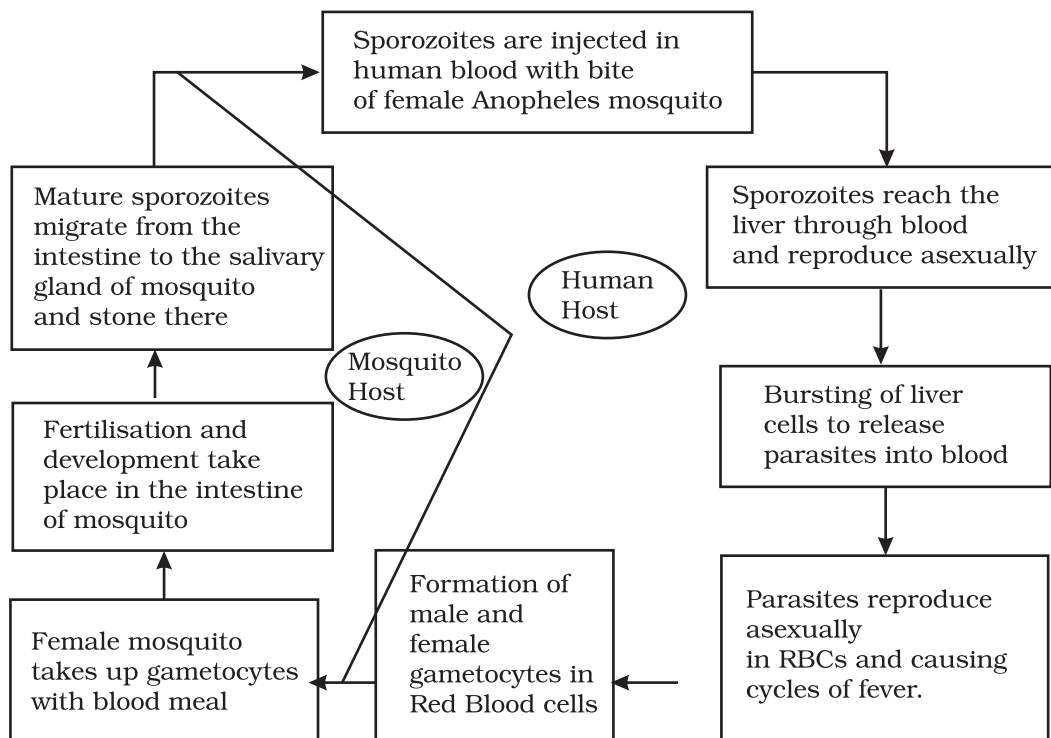

13. Why do some adolescents start taking drugs. How can the situation be avoided?

Ans. The reasons why adolescents and youngsters take to consumption of drugs are:

- i. Curiosity of child motivates him/her to experiment.
- ii. Need for adventure and excitement.
- iii. Peer group pressure.
- iv. Desire to do more physical and mental work.
- v. To overcome frustration and depression, due to failure in examinations or in other activities.
- vi. Unstable or unsupportive family structures.

The following measures can be taken to avoid taking drugs:

- i. Avoid undue pressure on child to perform beyond his/her capability in studies, sports or any other activities.
- ii. Education and counselling are very important to face problem of stress and failure in life.
- iii. Seeking help from parents, elders and peers. This would help the young to share their feelings and concern.
- iv. Looking for danger signs and taking appropriate measures to treat them.

v. Seeking professional and medical help for de-addiction and rehabilitation.

14. a. The shift from grain to meat diets creates more demands for cereals? Why?
 b. A 250 Kg cow produces 200 g of protein per day but 250 g of *Methylophilus methylotrophus* can produce 25 tonnes of protein. Name this emerging area of research. Explain its benefits.

Ans. a. It takes 3–10 kg of grain to produce 1 kg of meat using animal farming. This is why cereals demand increases.
 b. Production of single cell proteins (SCP) by microbes. Microbes are being grown on an industrial scale. *Spirulina* can be easily grown on starch, molasses etc., and can make food which is rich in proteins, minerals, fats, carbohydrates and vitamins. This could be a good alternative for dealing with the problem of malnutrition.

15. Draw a diagrammatic sketch of biogas plant, and label its various components.

Ans. Diagram of Biogas Plant from the textbooks

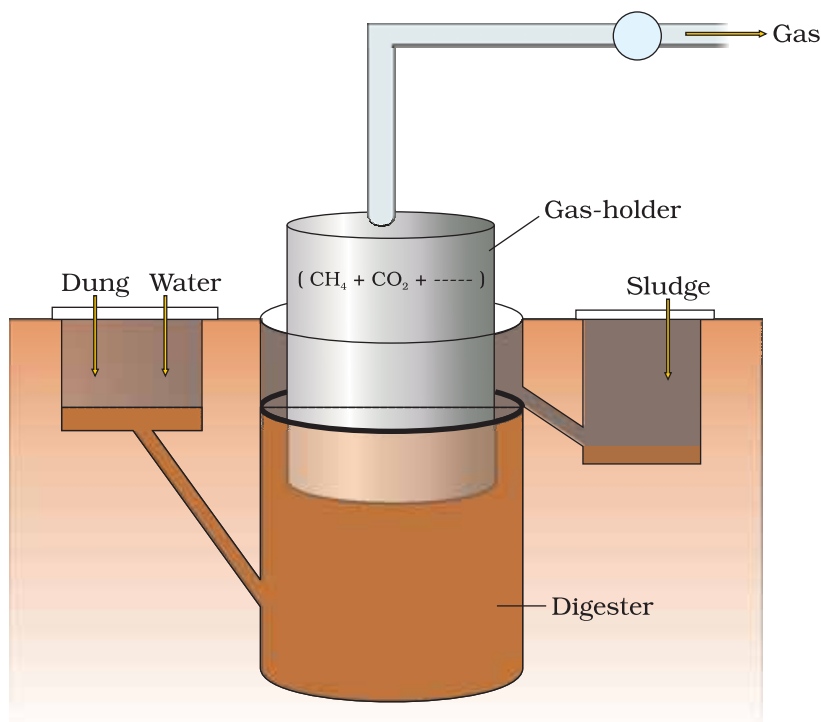

16. Describe critically the main ideas behind the biological control of pests and diseases.

Ans. Biological control means life against life. It's a natural and ecofriendly concept. It employs the natural organisms to control the population of pathogens and pests in an ecosystem. Classical examples are

Trichoderma which is antagonist against many soil borne plant pathogens. Similarly, *Penicillium* inhibits the growth of *Staphylococcus* and therefore has been successfully used in the production of Penicillin antibiotic to control many human bacterial pathogens.

17. For selection of recombinants, insertional inactivation of antibiotic marker has been superceded by insertional inactivation of a marker gene coding for a chromogenic substrate. Give reasons.

Ans. Selection of recombinants due to inactivation of antibiotics is a laborious process as it requires:

- (i) a vector with two antibiotic resistance marker
- (ii) preparation of two kinds of media plate, with one antibiotic each.

Transformed cells are first plated on that antibiotic plate which has not been insertional inactivated (ampicillin) and incubated overnight for growth of transformants. For selection of recombinants, these transformants are Replica plated on second antibiotic (tetracycline) plate (which got inactivated due to insertion of gene). Non-Recombinants grow on both the plates (one carrying ampicillin and the other carrying tetracycline) while recombinants will grow only on ampicillin plate.

This entire exercise is laborious and takes more time (two overnight incubation) as well. However, if we choose the second option (insertional inactivation of a marker that produces colour in the presence of a chromogenic compound), we can distinguish between the recombinants and non-recombinants on a single medium plate (containing one antibiotic and the chromogenic compound) after overnight growth. Hence would choose a marker which produces a coloured compound but gets inactivated due to insertion of foreign DNA.

18. Describe the role of *Agrobacterium tumefaciens* in transforming a plant cell.

Ans. *Agrobacterium tumefaciens* harbours a mega plasmid called Ti-plasmid. This has a T-DNA region flanked by left border and right border sequence. The T-DNA gets transferred and integrates with the host plant DNA. This property of Ti-plasmid has been exploited for cloning of gene of interest and stably integrating them in the plant genome. Therefore, by using Ti-plasmid or its derivatives, recombinant plant cells with desired genes of interest stably integrated in the plant genome has been successfully produced.

19. Define transgenic animals. Explain in detail any four areas where they can be utilised.

Ans. Transgenic animals are products of genetic engineering and express specific gene(s) from totally unrelated source. Following are the four main areas where they can be utilised.

1. To study normal physiology and development these animals can be used to study as to which factor / gene products are needed at what time of development. By expression of certain genes, they help scientists to understand the normal gene expression at various stages of growth and development.
 2. Study of Diseases
Transgenic animals can be created to serve as models for various human diseases. They also help us understand the involvement of various genes in diseases like cancer, Parkinson' disease etc.
 3. Vaccine safety
Transgenic animals can be used to test vaccines like polio vaccine. Transgenic mice have shown promising results in this area and would replace the vaccine testing on monkeys in the years to come.
 4. Chemical safety testing
Transgenic animals are created which are more sensitive to certain chemicals / drugs. These are used to study the toxicity or side effects of that chemical / drug. The advantage is that we get results faster.
3. You have identified a useful gene in a bacteria. Make a flow chart of the steps that you would follow to transfer this gene to a plant.

Ans. After identifying a useful gene in bacteria, following steps should be undertaken

1. Isolation of useful gene using Restriction Endonucleases
↓
2. Transferring the gene to a suitable vector to create a recombinant DNA molecule
↓
3. Transfer of these recombinant DNA molecules to the target cells
↓
4. Screening of cells for transformation
↓
5. Selection of transformed cells
↓
6. Regeneration of plants from the transformed cells to get transgenic plants.

20. List the disadvantages of insulin obtained from the pancreas of slaughtered cows and pigs:

Ans. 1. Insulin being a hormone is produced in very little amounts in the body. Hence, a large number of animals need to be sacrificed for obtaining small quantities of insulin. This makes the cost of insulin very high. [Demand being many fold higher than supply].

2. Slaughtering of animals is also not ethical.
3. There is potential of immune response in humans against the administered insulin which is derived from animals.
4. There is possibility of slaughtered animals being infested with some infectious micro organism which may contaminate insulin.

21. What do you understand by the term bio-pesticide? Name and explain the mode of action of a popular bio-pesticide.

Ans. Biopesticide is a pesticide which is

- a. not chemical in nature
- b. more specific in action against the pest
- c. safer for environment than chemical pesticides

A popularly known bio-pesticide is Bt toxin, which is produced by a bacterium called *Bacillus thuringiensis*. Bt toxin gene has been cloned from this bacterium and expressed in plants. Bt toxin protein when ingested by the insect, gets converted to its active form due to the alkaline pH of the gut. The activated toxin binds to the surface of midgut epithelial cells and create pores that cause cell swelling and lysis and eventually kills the insect.

22. Name the five key tools for accomplishing the tasks of recombinant DNA technology. Also mention the functions of each tool.

- Ans.
- i. Restriction endonucleases: for cutting the desired DNA at desired places
 - ii. Gel electrophoresis: for separating the desired DNA fragments
 - iii. Ligase enzyme: for creating recombinant DNA molecule.
 - iv. DNA delivery system: like electroporation, microinjection, gene gun method.
 - v. Competant host (usually bacteria / yeast): to take up recombinant DNA.

23. Comment on the following diagrams:

A, B, C, D, G, P, Q, R, S are species

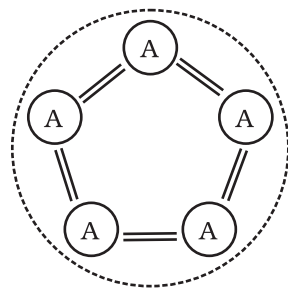

I

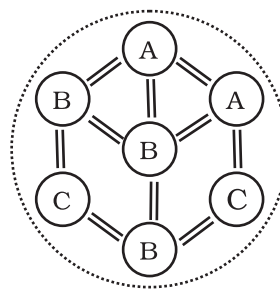

II

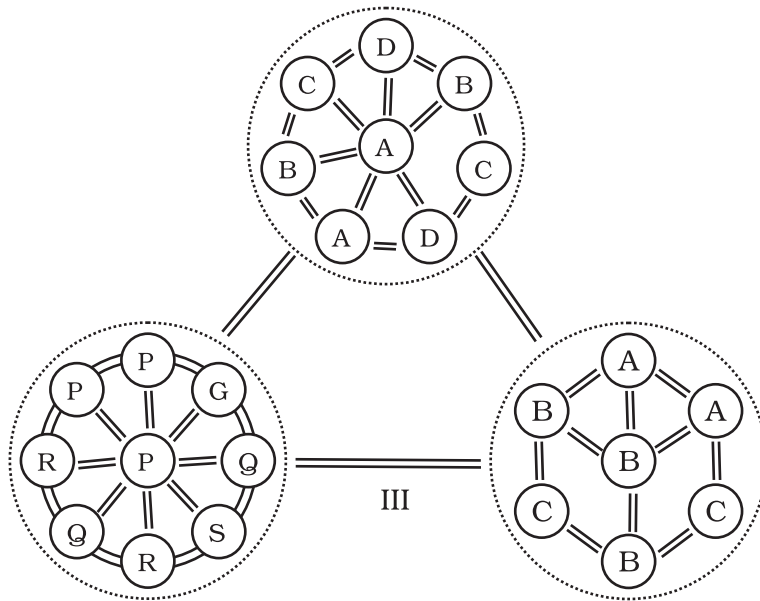

Ans.

Fig. I: It is a single population and all individuals are of the same species i.e. A. Individual interact among themselves and their environment.

Fig. II: It is a community and it contains three populations of species A,B and C. They interact with each other and their environment.

Fig. III: It is a biome. It contains three communities. of which one is in climax and other two are in different stages of development. All three communities are in the same environment and they interact with each other and their environment.

24. The following diagrams are the age pyramids of different populations. Comment on the status of these populations.

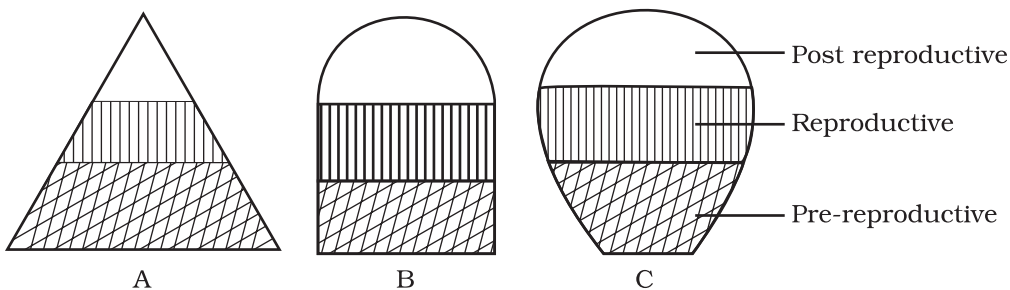

Fig.A: It is a pyramid shaped age pyramid. In this figure, the base i.e pre-reproductive stage is very large when compared with the reproductive and past reproductive stages of the population. This type of age structure indicates that the population would increase rapidly.

Fig.B: It is an inverted bell shaped pyramid. In this figure, the pre-reproductive and reproductive stages are same. This type of age structure indicates that the population is stable.

Fig.C: It is 'Urn' shaped pyramid. In this figure, the pre-reproductive and reproductive stages are less than the post reproductive stage of this population. In this population more older people are present. This type of age structure indicates that the population definitely is declining.

25. In an aquarium two herbivorous species of fish are living together and feeding on phytoplanktons. As per the Gauss's principle, one of the species is to be eliminated in due course of time, but both are surviving. How? And what possibly happened to both the species?

Ans. Each species has a specific position or functional role within the community, called niche. According to the Gauss's principle, no two species can live in the same niche. In this case, two herbivorous species are living in the same niche and feeding on phytoplanktons. It may be because of the availability of sufficient phytoplanktons/and or less number of individuals of the fish species. One of the two species might have occurred. And though neither of the species have been eliminated, niche overlapping may affect the growth and development of individuals of the species.

26. What will happen to an ecosystem if

- a. All producers are removed;
- b. All organisms of herbivore level are eliminated; and
- c. All top carnivore population is removed

Ans. (a) Reduction in primary productivity. No biomass available for consumption by higher trophic levels / heterotrophs
 (b) Increase in primary productivity and biomass of producers. Carnivores population will subsequently dwindle due to food shortage.
 (c) Increase in number of herbivores
 Overgrazing by herbivores
 Desertification

27. Elaborate how invasion by an alien species reduces the species diversity of an area.

Ans. Some possible explanations are that the alien species may be

- i. Vigorously growing and compete with the natural plants for minerals, water etc. The less vigorous local species may be eliminated.
- ii. Natural pests and predators of the alien species may not be present in the introduced area-leading to proliferation in their number.

- iii. The introduced species may harm the local species by production of chemicals (Amensalism)
- iv. The alien species by proliferation may make conditions unfavourable for the growth of local native plants. (eg. *Eichornia*)

28. How can you, as an individual, prevent the loss of biodiversity?

Ans. The loss of biodiversity can be prevented by

- i. Practise of recycling waste paper etc.
- ii. Judicious exploitation of medicinal and commercial plants and animals.
- iii. Generating awareness among the public on the importance of biodiversity, conversation through skits, screening of films, lectures etc.

Teaching people how to reduce green house gases emissions, through alternate eco friendly green technologies like use of solar energy, wind energy, biogas, vermi compost, organic farming etc.

29. Write a short note on electronic waste. List the various sources of e- wastes and the problems associated with the disposal of e-waste.

Ans. Discarded unusable electronic gadgets such as computers, mobile phones, circuits, television sets, etc., form electronic waste. These contain harmful toxic substances like heavy metals to which the unskilled manual workers are directly exposed.

30. What are the basic characteristics of a modern land fill sites. List any three and mention the reasons for their use.

Ans. Characteristics of a modern land fill include

- i. Methods to contain leachate such as lining clay or plastic liners.
- iii. Compaction and covering of the waste to prevent it being blown by wind.
- iv. Installation of a land fill gas extraction system to extract the gas for use in generation of power.

MODEL QUESTION PAPER

This chapter deals with the design of Model Question Paper of Biology for Class XII. This design is based on model question paper of Biology for Class XII on NCERT web site (www.ncert.nic.in). Very Short Answer (VSA) type questions of two marks each are included in the present design and Multiple Choice Question (MCQ) of one mark each is also suggested. This chapter is divided into three parts, such as Design of the Question Paper, Model Questions and Answers with Marking Scheme.

I DESIGN OF THE QUESTION PAPER

In order to develop a balance question paper various parameters are taken into consideration. These are the type of questions, marks allocation, number of questions, time allocation, chapterwise distribution of topics, difficulty level etc. An attempt has been made to provide proper weightage to these parameters under four separate sub-headings.

Type of Questions and Marking

1. Multiple Choice Questions (MCQ) (1) mark
2. Very Short Answer Type Questions (VSA) (2) marks
3. Short Answer Type Questions (SA) (3) marks
4. Long Answer Type Questions (LA) (5) marks

Number, Marks and Time Allocation to Each Type of Questions

Type and Marks	Time in Minutes	Number of Questions	Marks distribution	Time distribution
MCQ - 1 mark	2	10	$10 \times 1 = 10$	$10 \times 2 = 20$
VSA - 2 marks	5	12	$12 \times 2 = 24$	$12 \times 5 = 60$
SA - 3 marks	8	7	$7 \times 3 = 21$	$7 \times 7 = 49$
LA - 5 marks	12	3	$3 \times 5 = 15$	$3 \times 12 = 36$
Total		Questions 32	Marks 70	Minutes 165

Unit-wise Distribution of the Questions and Marks

Unit	Unit wise Questions of each type and marks in()				Unit wise Distribution of total question and marks	
	MCQ	VSA	SA	LA	Total No. Question	Total Marks
Reproduction	3 (3)	1 (2)	2 (6)	1 (5)	7	16
Genetics and Evolution	3 (3)	2 (4)	2 (6)	1 (5)	8	18
Biology in Human Welfare	1 (1)	4 (8)	1 (3)	-	6	12
Biotechnology	1 (1)	2 (4)	2 (6)	-	5	11
Ecology	2 (2)	3 (6)	-	1 (5)	6	13
Total	10	12	7	3	32	70

Difficulty Level of the Question

Easy (E) - 20% = 14 marks

Average (A) - 60% = 42 marks

Difficult (D) - 20% = 14 marks

MODEL QUESTIONS**MULTIPLE CHOICE QUESTION (MCQ's)****Mark 01**

Tick the correct statement

- During microsporogenesis, meiosis occurs in:
 - Endothecium
 - Microspore mother cells
 - Microspore tetrads
 - Pollen grains.
- Which one of the following is not a male accessory gland?
 - Seminal vesicle
 - Ampulla
 - Prostate
 - Bulbourethral gland

3. Which of the following statements is correct?
 - a. Surgical methods of contraception does not prevent gamete formation
 - b. In E. T techniques, embryos are always transferred into the uterus
 - c. Oral pills are very popular contraceptives among the rural women
 - d. All STDs are completely curable

4. The synthesis of DNA is discontinuous on one strand of the replication fork because:
 - a. DNA molecule being synthesised is very long
 - b. DNA-dependent DNA polymerase catalyse polymerisation only in one direction ($5' \rightarrow 3'$)
 - c. It is more efficient process
 - d. It help to use DNA ligase

5. To analyse the genotype of an organism, it is made to:
 - a. Self cross
 - b. Cross with recessive parent
 - c. Cross with dominant parent
 - d. Cross with another species

6. The conditions of the earth atmosphere conducive for the origin of life were:
 - a. Presence of high temperature, CH_4 , NH_3 , and O_3
 - b. High temperature, CH_4 , NH_3 , volcanic eruption
 - c. High temperature, volcanic eruption, O_2 , NH_3
 - d. Volcanic eruption, CH_3 , NH_3 and O_2

7. Virus-free plants can be raised *in vitro* from
 - a. Any plant part
 - b. Meristems of infected plants
 - c. Stem of infected plants
 - d. Leaves of infected plants

8. If a radiolabel is used to tag a DNA molecule, the technique used to localise would be
 - a. X-ray crystallography
 - b. Autoradiography
 - c. Fluorescence microscopy
 - d. Electron microscopy

9. An inverted Pyramid of biomass is represented by:
- Aquatic ecosystem
 - Ecosystem of a big tree
 - Grassland ecosystem
 - Tropical fresh ecosystem
10. Some of the problems that have come in the wake of green revolution are:
- Water logging and permafrost
 - Soil erosion and desertification
 - Water logging and soil salinity
 - Snow blindness and water logging

VERY SHORT ANSWER TYPE QUESTIONS (VSA)**Marks 02**

- Right two important conditions of MTP to avoid its misuse.
- Which of the following are homologous or analogous (Indicate H for homologous and A for Analogous)
 - Wing of bat and butterfly _____
 - Wing of bat and flipper of whale _____
 - Wing of butterfly and flipper of whale _____
 - Flipper of whale and wing of bird _____
- How does incomplete dominance differ from co-dominance?
- The yellowish fluid colostrum is secreted by mother during initial days of lactation, mention the antibody present in it and mention the type of immunity.
- With the help of a suitable example mention the role of microbes in:
 - Single cell protein
 - Organic farming
- Differentiate between
 - Benign and malignant tumours
 - Viral oncogenes and protooncogenes
- Name the microbe used for production of Swiss cheese.
- How does human insulin formed using rDNA technique?
- What are selectable markers? Give two example.
- Differentiate between
 - Grazing food chain and Detritus food chain
 - Gross primary productivity and Net primary productivity

11. Arrange the following steps of decomposition in a sequential order:
Catabolism, Leaching, Mineralisation, Humification and Fragmentation.
12. Write the appropriate method for disposals of e-waste.

SHORT ANSWER TYPE QUESTIONS (SA)**MARKS 03**

1. The number of taxa exhibiting asexual reproduction is drastically reduced in higher plants (angiosperms) and higher animals (vertebrates) as compared with lower groups of plants and animals. Analyse the possible reasons for this situation.
2. Corpus luteum in pregnancy has a long life. However, if fertilisation does not take place, it remains active only for 10-12 days. Explain.
3. Why is the frequency of red-green colour blindness many times higher in males than in the females?
4. DNA is more suitable genetic material over RNA. Why?
5. A sportsperson was tested positive for cannabinoid. What are these? From where are these extracted? What are its effects on human body?
6. What is Bt toxin? Name an organism that produces it? How has man exploited it?
7. Discuss in detail how RNA can be used to silence specific genes.

LONG ANSWER TYPE QUESTIONS (LA)**Marks 05**

1. Draw a neat, labelled diagram of a mature angiosperm, embryo sac. Mention the role of synergids.
OR
Enumerate and describe any five reasons for introducing sex education to school-going children.
2.
 - a. In humans, males are heterogametic and females are homogametic. Explain. Are there any examples where males are homogametic and females heterogametic?
 - b. Who determines the sex of an unborn child? Mention whether temperature has a role in sex determination.

OR

Give an account of post transcriptional modifications of a eukaryotic mRNA with diagrammatic representation.

3. Observe the diagram given below and answer the following.

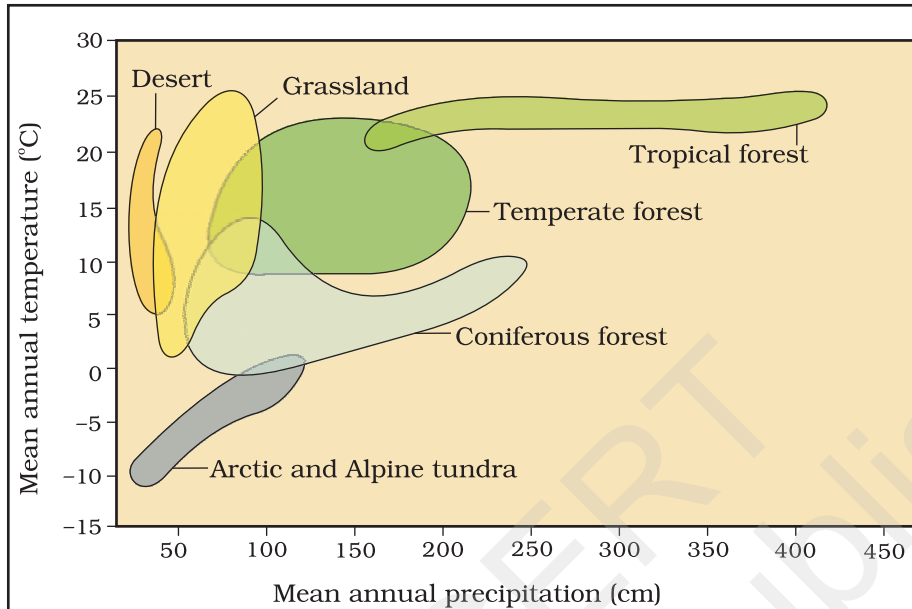

- Which biome shows maximum range of annual precipitation?
- Which biome shows maximum range of annual temperature?
- Give range of mean annual temperature by coniferous forest
- Give range of mean annual precipitation by temperate forest
- Which biome has lowest mean annual temperature?

OR

Every year in winter Siberian cranes migrate from Russia to India for breeding. In the year 2006, a survey was done which has the values in the given equation

$$N_{(t+1)} = N_t + \{(B+I)-(D+E)\} \text{ as follows}$$

$$N_{(t+1)} = 1200 + \{(600+700)-(200+800)\}$$

On the basis of above answer the followings

- Natality rate
- Mortality rate
- Number of cranes immigrated
- Number of cranes emigrated
- Population of cranes in India in year 2006.

ANSWER WITH MARKING SCHEME

Answers	Marking Scheme
MCQ: 1 Mark	
1. b — Microspore mother cells	1
2. b — Ampulla	1
3. a — Surgical methods of contraception does not prevent gamete formation	1
4. b — DNA-dependent DNA polymerase catalyse polymerisation only in one direction (5' → 3')	1
5. b — Cross with recessive parent	1
6. b — High temperature, CH ₄ , NH ₃ , volcanic eruption	1
7. b — Meristems of infected plants	1
8. b — Autoradiography	1
9. a — Aquatic ecosystem	1
10. c — Water logging and soil salinity	1
	10

VERY SHORT ANSWER TYPE QUESTIONS (VSA)**Marks 02**

1. Illegal female foeticides, Misuse of amniocentesis	1+1
2. a — A	½
b — H	½
c — A	½
d — H	½
3. Incomplete dominance	Co-dominance 1+1
(i) One allele is incompletely dominant over the other	(i) Both alleles are dominants and express themselves
(ii) Phenotype of F ₁ is an intermediate of the two parents	(ii) Phenotype of F ₁ resembles both parents
4. IgA antibody is present Innate immunity and Passive immunity	1+1
5. a. Spirulina; nutritious food	
b. Rhizobium or Azobacter; Biofertiliser	1+1

6. a. Non cancerous; cancerous
b. Virus causing cancer; normal cell can be activated to cancerous. 1+1
7. *Propionibacterium sharmanii* 2
8. Gens for 'A' and 'B' chains of human insulin are introduced in E.coli. $\frac{1}{2}$
Both 'A' and 'B' chains are produced separately. $\frac{1}{2}$
It is extracted and combined by creating disulphide bond to form human insulin. 1
9. Selectable marker permits the growth of the transformants. 1
Ampicillin and tetracycline. $\frac{1}{2}+\frac{1}{2}$
10. a. The grazing food chain begins with living organism called as producers and detritus food chain begins with dead organic matter $\frac{1}{2}+\frac{1}{2}$
b. Rate of production of organic matter during photosynthesis. $\frac{1}{2}+\frac{1}{2}$
Gross primary productivity minus respiration loss.
11. Fragmentation, Leaching, catabolism, humification, mineralisation 2
12. Recycling 2

SHORT ANSWER TYPE QUESTIONS (SA)**Marks 03**

1. Both angiosperms and vertebrates have a more complex structural organisation. They have evolved very efficient mechanism of sexual reproduction. Since asexual reproduction does not create new genetic pools in the offspring and consequently hampers their adaptability to external conditions, these groups have resorted to reproduction by sexual methods. 3
2. During pregnancy (in presence of Zygote) the maternal endometrium sends a neural signal to hypothalamus to sustain the gonadotropin (LH) secretion. This maintains the corpus luteum. In the absence of a zygote, however the corpus luteum can not be maintained longer because of the absence of signal. 3
3. For becoming colourblind, the female must have the allele for it in her both X-chromosomes; but males develop colourblindness when their sole chromosome has the allele for it. 3
4. DNA is a more suitable genetic material than RNA, because it is chemically less reactive and structurally more stable. 3
5. They are a group of chemical that interact with cannabinoid receptors present in the brain
cannabis sativa; Flower and leaves
stimulates body, effect cardio-vascular system 1+1+1

6. Cry protein
Bacillus thuringiensis
As biopesticide in cotton plant 1+1+1
7. RNA can be used to silence certain specific genes through the process of RNA interference (RNAi), a process of cellular defence in all eukaryotic organisms. In this method a ds RNA binds to a specific site in the mRNA and silences it by preventing its translation. 3

LONG ANSWER TYPE QUESTIONS (LA)**Marks 05**

1.

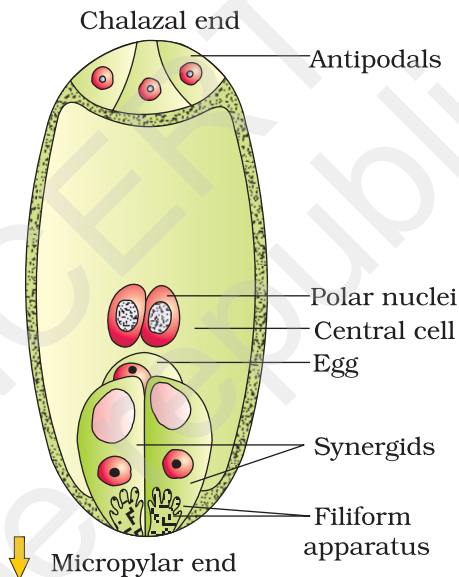

Synergids have special cellular thickenings at the micropylar tip which play an important role in guiding the pollen tubes into the synergid.

3+2

OR

(a) Proper information about reproductive organs-physiology and functioning; (b) Discourage myths and misconceptions about sex-related aspects; (c) Knowledge about safe and hygienic sexual practices; (d) Adolescence related changes, (e) Prevention of STDs, AIDS etc.

1×5

2. (a) The terms homogametic and heterogametic refer to the organisms depending upon whether all the gametes contain one type of sex chromosome (Homo = same) or two different types of sex chromosomes (Hetero = different). Humans show XX / XY type of sex determination i.e. females contain two copies of X chromosome and males contain one X

and one Y chromosome. Therefore, ova produced by females contain the same sex chromosome i.e. X. On the other hand the sperms contain two different types of chromosomes i.e. 50% sperms have X and 50% have Y chromosome. Therefore, in case of humans, females are considered to be homogametic while males are heterogametic. $2\frac{1}{2}$

There are examples where males are homogametic and females are heterogametic. In some birds the mode of sex determination is denoted by ZZ (males) and ZW (females). 1

- (b) As a rule the heterogametic organism determines the sex of the unborn child. In case of humans, since males are heterogametic it is the father, and not the mother, who decides the sex of the child. In some animals like crocodiles, temperature plays a role in sex determination. Lower temperature favours hatching of female offsprings and higher temperatures lead to hatching of male offsprings. $1\frac{1}{2}$

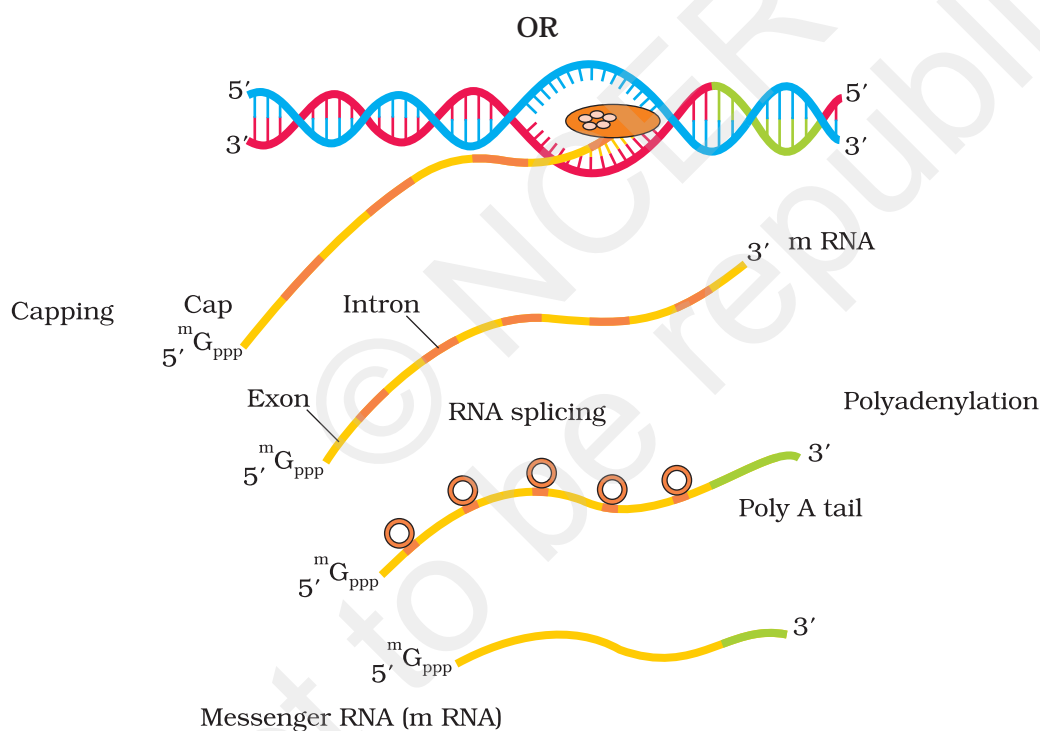

$2\frac{1}{2}$

The primary transcripts (hnRNA) contain both the exons and the introns and are non-functional. Hence, it is subjected to a process called splicing where the introns are removed and exons are joined in a defined order. hnRNA undergo two additional processing called as capping and tailing. In capping an unusual nucleotide (methyl guanosine triphosphate) is added to the 5'-end of hnRNA. In tailing, adenylate residues (200-300) are added at 3'-end in a template independent manner. It is the fully processed hnRNA, now called mRNA, that is transported out of the nucleus for translation. $2\frac{1}{2}$

EXEMPLAR PROBLEMS IN BIOLOGY - CLASS XII
(Corrections in the questions)

Chapter 1

Reproduction in Organisms

Multiple Choice Questions

3. Asexual method of reproduction by binary fission is common to which of the following?
- Some eukaryotes
 - All eukaryotes
 - Some prokaryotes
 - All prokaryotes

Options

- i and ii
- ii and iii
- i and iii
- iii and iv

11.

Choose the correct answer from the options given below:

- | | |
|-------------------|-------------------|
| a. i, ii and iii; | b. i, iii and iv |
| c. i, ii and iv | d. ii, iii and iv |

Chapter 3

Human Reproduction

Multiple Choice Questions

1.

- c. Polyspermy in mammals is prevented by the chemical changes in the egg surface

2. Identify the correct statement from the following:

- High levels of estrogen triggers the ovulatory surge.
- Oogonial cells start to proliferate and give rise to functional ova in regular cycles from puberty onwards.
- Sperms released from seminiferous tubules are highly motile.
- Progesterone level is high during the post ovulatory phase of menstrual cycle.

Chapter 5

Principle of Inheritance and Variation

Multiple Choice Questions

15. It is said that Mendel proposed that the factor controlling any character is discrete and independent. His proposition was based on the
- results of F_3 generation of a cross.
 - observations that the offspring of a cross made between the plants having two contrasting characters shows only one character without any blending.
 - self pollination of F_1 offsprings.
 - cross pollination of F_1 generation with recessive parent.

Chapter 6

Molecular Basis of Inheritance

Multiple Choice Questions

24. The RNA polymerase holoenzyme transcribes
- the promoter, structural gene and the terminator region.
 - the promoter and the terminator region.
 - the structural gene and the terminator region.
 - the structural gene only.

Chapter 7

Evolution

Multiple Choice Questions

- 15.
- Chimpanzee

Chapter 8

Human Health and Diseases

Multiple Choice Questions

5. The sporozoites that cause infection, when a female *Anopheles* mosquito bites a person, are formed in
- liver of the person
 - RBCs of mosquito
 - salivary glands of mosquito
 - intestine of mosquito
- 11.
- the ability to differentiate pathogens or foreign molecules from self cells increases.
19. Which of the following is not a lymphoid tissue?
- Spleen
 - Tonsils
 - Pancreas
 - Thymus
21. Haemozoin is a
- precursor of hemoglobin
 - toxin released from *Streptococcus* infected cells
 - toxin released from *Plasmodium* infected cells
 - toxin released from *Haemophilus* infected cells

Chapter 9

Strategies for Enhancement in Food Production

Multiple Choice Questions

- 1.
- Relation of heterogenous populations to its environment.

- 13.
- a. i and iii
 - b. i and ii
 - c. i and iv
 - d. ii and iii
- 16.
- d. aromatic amino acids
- 20.
- a. Bamboo
23. The agriculture sector of India employs about
- a. 50 per cent of the population
 - b. 70 per cent of the population
 - c. 30 per cent of the population
 - d. 60 per cent of the population

Chapter 10

Microbes in Human Welfare

Multiple Choice Questions

- 2.
- a. anaerobic digesters
 - b. floc
19. Delete the question

Chapter 11

Biotechnology: Principles and Processes

Multiple Choice Questions

6. Which of the following is not required in the preparation of a recombinant DNA molecules?
- a. Restriction endonuclease
 - b. DNA ligase
 - c. DNA fragments
 - d. *E. coli*
14. Which of the following is not a source of restriction endonuclease?
- a. *Haemophilus influenza*
 - b. *Escherichia coli*
 - c. *Entamoeba coli*
 - d. *Bacillus amyloliquifaciens*

Chapter 12

Biotechnology and its Applications

Multiple Choice Questions

7. The site of production of ADA in the body is
- a. Erythrocytes
 - b. Lymphocytes

- c. Blood plasma
 - d. Osteocytes
15. Silencing of a gene could be achieved through the use of
- a. RNAi only
 - b. antisense RNA only
 - c. both RNAi and antisense RNA
 - d. none of the above

Chapter 15

Biodiversity and Conservation

Multiple Choice Questions

5. Which of the following is not a feature of biodiversity hotspots?
- a. Large number of species
 - b. Abundance of endemic species
 - c. Mostly located in the polar regions
 - d. Mostly located in the tropics
17. Which of the following group exhibit more species diversity?
- a. Gymnosperms
 - b. Algae
 - c. Bryophytes
 - d. Fungi

Chapter 17

Answers to Multiple-choice Questions (Corrections in the answers)

Chapter 3: Human Reproduction

2-d

Chapter 5: Principle of Inheritance and Variation

3-a; 16-d

Chapter 8: Human Health and Diseases

5-d

Chapter 9: Strategies in Enhancement of Food Production

15-a

Chapter 10: Microbes in Human Welfare

2-a

Chapter 13: Organisms and Populations

5-d; 17-b; 20-a

Chapter 15: Biodiversity and Conservation
13-c

Chapter 16: Environmental Issues
10-a

© NCERT
not to be published